

Operation Manual

Control Module & Hydraulic Tower & Hydraulic Station

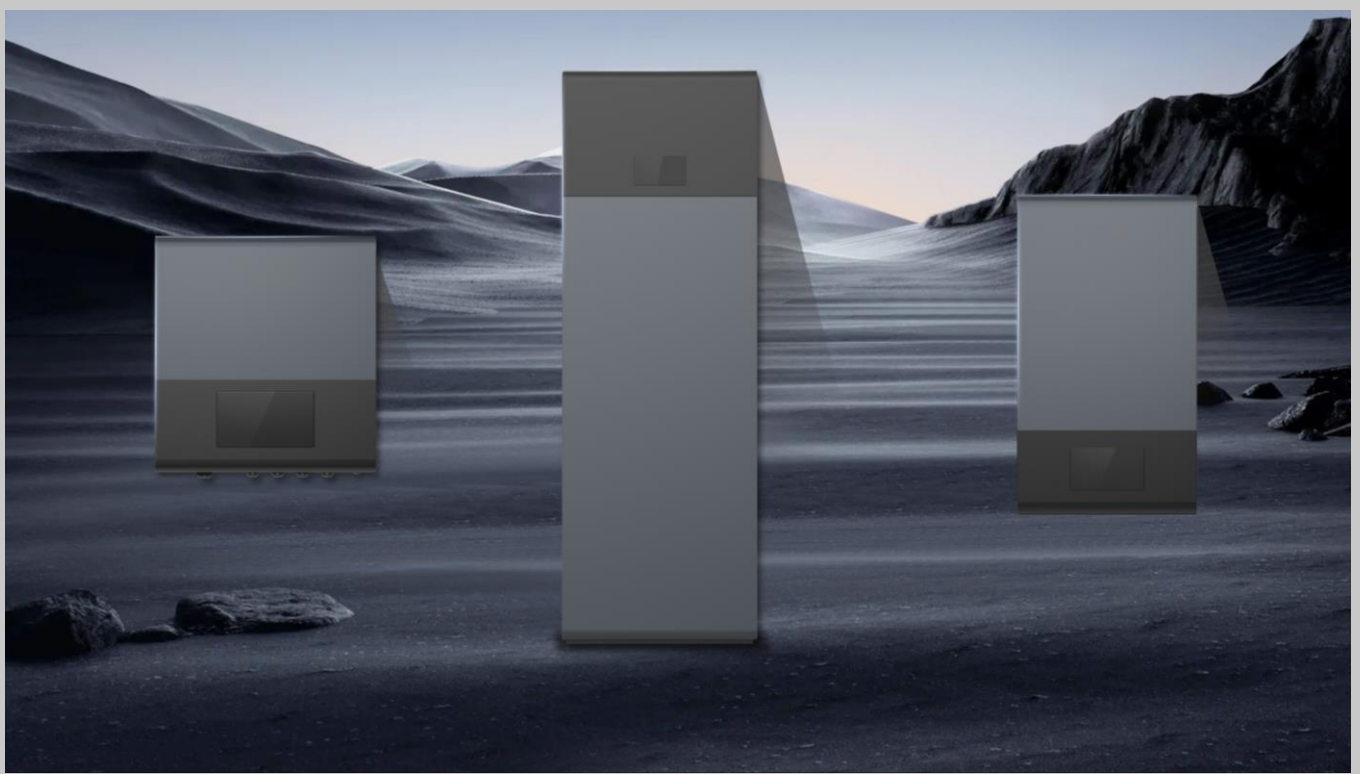

IMPORTANT NOTE:

Thank you very much for purchasing our product. Before using your unit, please read this manual carefully and keep it for future reference.

CONTENTS

1. HYDRAULIC MODULE & CONTROL MODULE UNIT	1
1.1. FOREWORD	1
1.2. OVERVIEW OF THE UNIT	3
1.2.1. Dimensions.....	3
1.2.2. Main Parts of the Unit.....	5
1.3. INSTALLATION AND CONNECTION	8
1.3.1. Installation.....	8
1.3.2. Before Wiring	10
1.3.3. Electrical Connection	11
2. CONTROLLER OPERATION	19
2.1. GENERAL SAFETY PRECAUTIONS.....	19
2.1.1. About The Documentation.....	19
2.1.2. For The User	19
2.2. Power On Interface	20
2.2.1. The Appearance of The Wired Controller	20
2.2.2. Status Icons	22
2.3. WIRE CONTROLLER OPERATION GUIDANCE	23
2.3.1. Single/Double Zone	23
2.3.2. No Hot Water in Single Zone A.....	23
2.3.3. Single Zone A + Hot Water	23
2.3.4. No Hot Water in Double Zone.....	23
2.3.5. Double Zone + Hot Water	24
2.3.6. Lock/Unlock Function	24
2.3.7. Setting Mode.....	24
2.3.8. Setting Target Temperature.....	25
2.3.9. Screen Saver / Screen Off.....	25
2.3.10. Fault Display	25
2.3.11. Check Parameter Status	25
2.3.12. Parameter Setting Interface	26
2.3.13. Setting Interface.....	26
2.3.14. Curve	28
2.3.15. Time Setting	28
2.3.16. Manual Mute	28
2.3.17. Timed Function	29
2.3.18. Heating Function.....	31
2.3.19. Preheat Function.....	32
2.3.20. Water Pump Operation Mode	32
2.3.21. Climate Curve.....	33
2.4. APPENDIX	37
2.4.1. Parameters	37
2.4.2. Error code.....	41
2.5. Wi-Fi FUNCTION	49

2.5.1. Software Installation	49
2.5.2. Login / Registration	49
2.5.3. Add Device	50
2.5.4. Software Function Operation.....	53
2.5.5. Modify Device Name / Delete Device	55
2.5.6. Mode settings	55
2.5.7. Timing.....	56
2.5.8. Set Parameters	57
2.5.9. Mine	58
3. Remove Procedures for Modules.....	59
3.1. Control Module	59
3.2. Hydraulic Module	60
3.3. DHW Hydraulic Module	63

1. HYDRAULIC MODULE & CONTROL MODULE UNIT

1.1.FOREWORD

WARNING

- Before touching electric terminal parts, turn off power switch.
- When service panels are removed, live parts can be easily touched by accident.
- Never leave the unit unattended during installation or servicing when the service panel is removed.
- Do not touch water pipes during and immediately after operation as the pipes may be hot and could burn your hands. To avoid injury, give the piping time to return to normal temperature or be sure to wear protective gloves.
- Do not touch any switch with wet fingers. Touching a switch with wet fingers can cause electrical shock.
- Before touching electrical parts, turn off all applicable power to the unit.

CAUTION

- Tear apart and throw away plastic packaging bags so that children will not play with them. Children playing with plastic bags face danger of death by suffocation.
- Safely dispose of packing materials such as nails and other metal or wood parts that could cause injuries.
- Ask your dealer or qualified personnel to perform installation work in accordance with this manual. Do not install the unit by yourself. Improper installation could result in water leakage, electric shocks or fire
- Be sure to use only specified accessories and parts for installation work. Failure to use specified parts may result in water leakage, electric shocks, fire, or the unit falling from its mount.
- Install the unit on a foundation that can withstand its weight. Insufficient physical strength may cause the equipment to fall and possible injury.
- Perform specified installation work with full consideration of strong wind, hurricanes, or earthquakes. Improper installation work may result in accidents due to equipment falling.
- Make certain that all electrical work is carried out by qualified personnel according to the local laws and regulations and this manual using a separate circuit. Insufficient capacity of the power supply circuit or improper electrical construction may lead to electric shocks or fire.
- Be sure to install a ground fault circuit interrupter according to local laws and regulations. Failure to install a ground fault circuit interrupter may cause electric shocks and fire.
- Make sure all wiring is secure. Use the specified wires and ensure that terminal connections or wires are protected from water and other adverse external forces. Incomplete connection or affixing may cause a fire.
- When wiring the power supply, form the wires so that the front panel can be securely fastened. If the front panel is not in place there could be overheating of the terminals, electric shocks or fire.

- After completing the installation work, check to make sure that there is no refrigerant leakage.
- Never directly touch any leaking refrigerant as it could cause severe frostbite. Do not touch the refrigerant pipes during and immediately after operation as the refrigerant pipes may be hot or cold, depending on the condition of the refrigerant flowing through the refrigerant piping, compressor and other refrigerant cycle parts. Burns or frostbite are possible if you touch the refrigerant pipes. To avoid injury, give the pipes time to return to normal temperature or, if you must touch them, be sure to wear protective gloves.
- Do not touch the internal parts (pump, backup heater, etc.) during and immediately after operation. Touching the internal parts can cause burns. To avoid injury, give the internal parts time to return to normal temperature or, if you must touch them, be sure to wear protective gloves.

1.2.OVERVIEW OF THE UNIT

1.2.1. Dimensions

Hydraulic Module

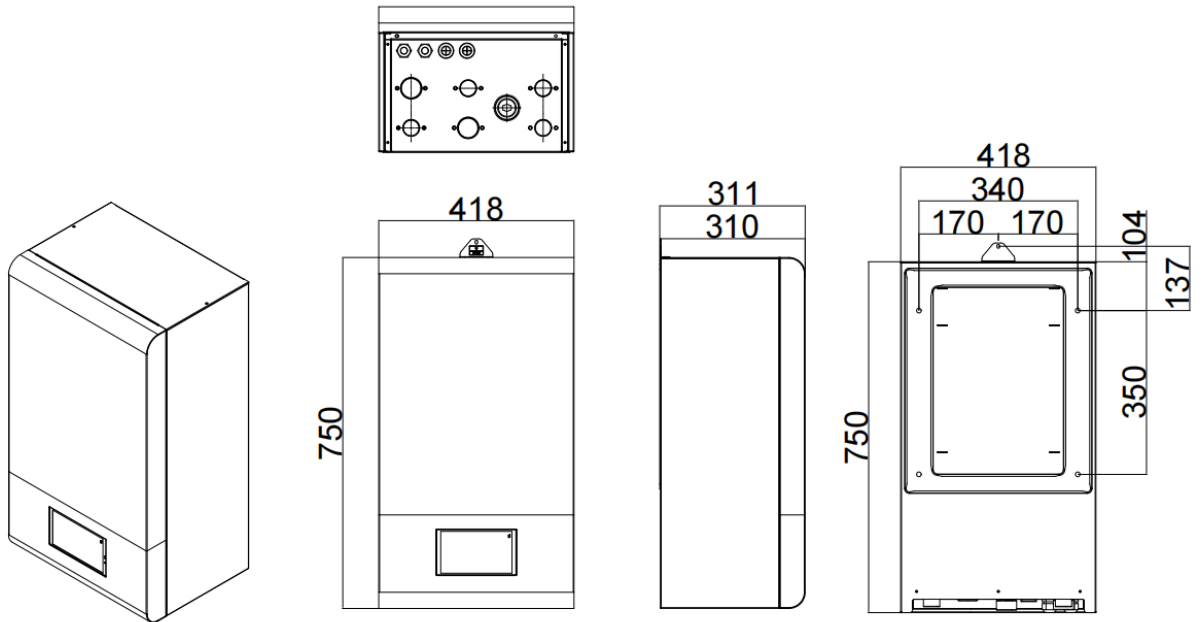

Control Module

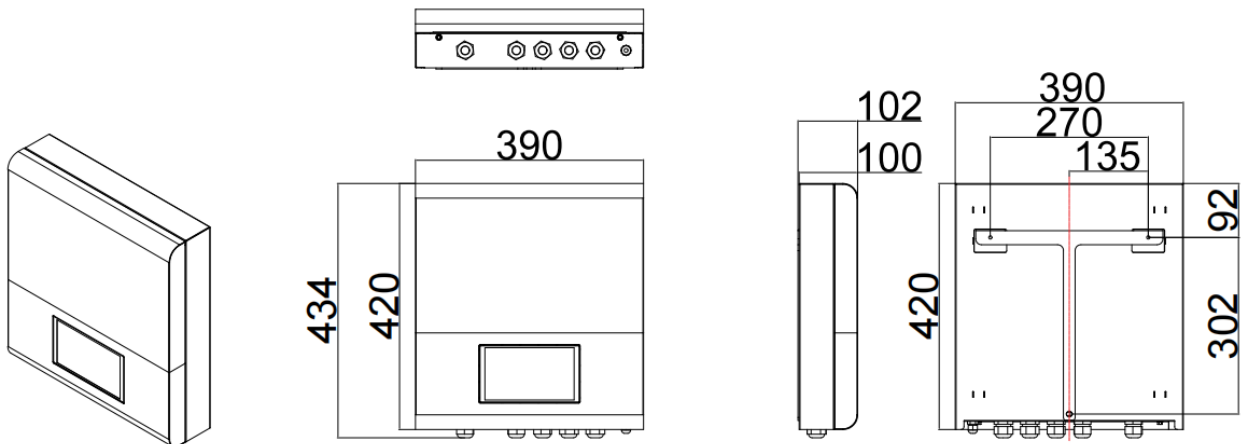

DHW Hydraulic Module

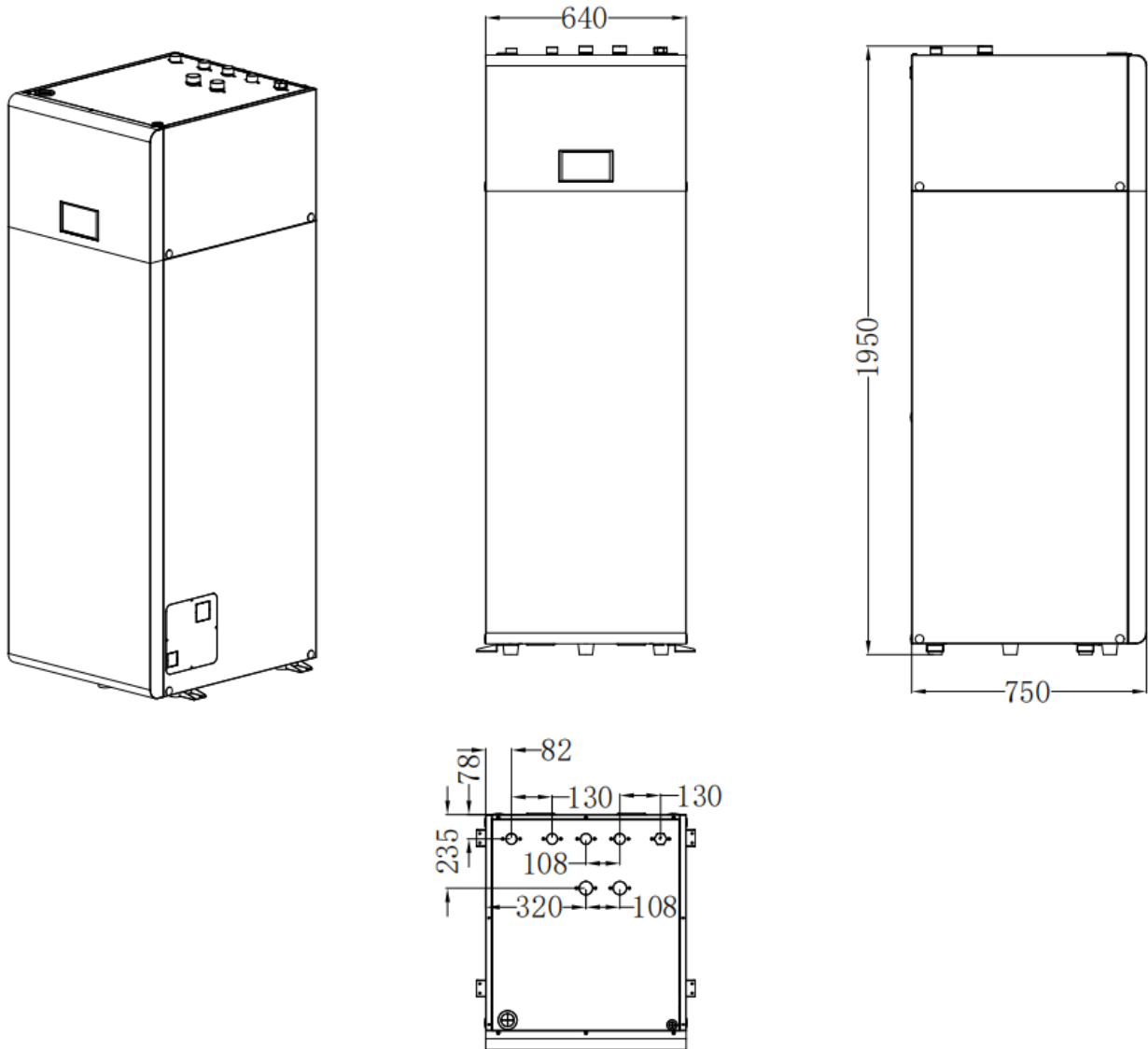

1.2.2. Main Parts of the Unit

Hydraulic Module

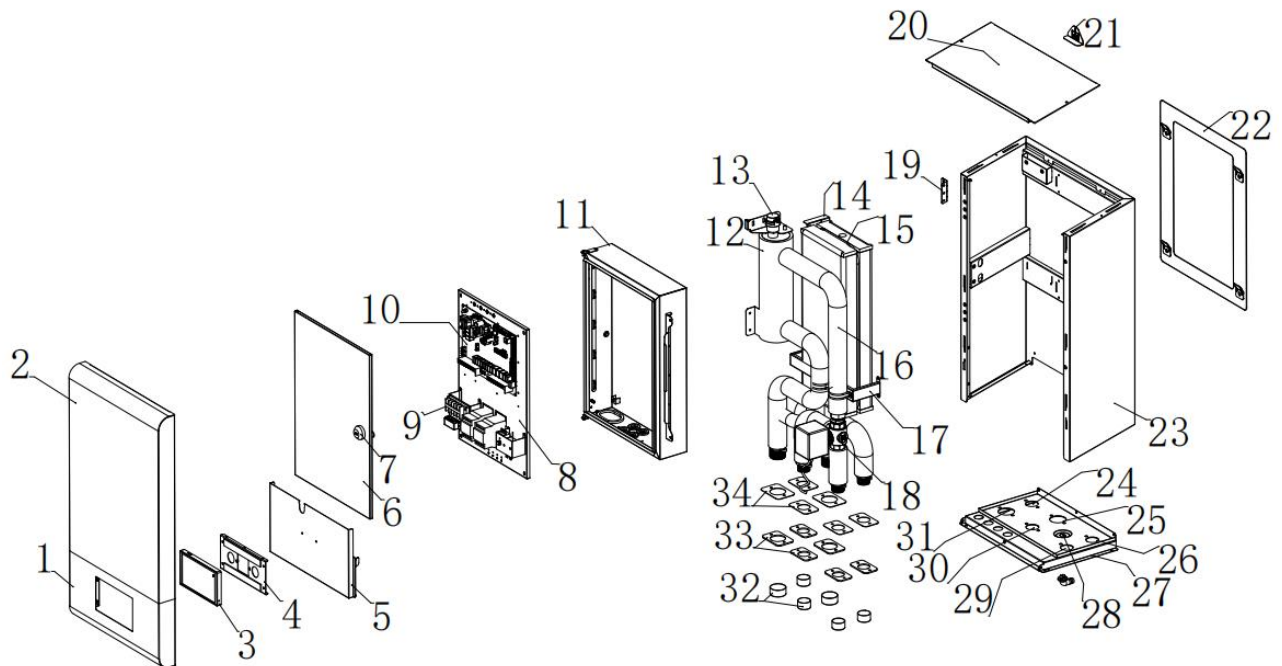

1	Front Panel 1	13	Exhaust Valve	25	Hp Water Outlet
2	Front Panel 2	14	Fixing Panel 2	26	Heating Inlet
3	Wire Controller	15	Expansion Tank	27	Chassis
4	Fixing Panel 1	16	Water Pipe Assembly	28	Condensate Drain
5	Cover Panel 1	17	Fixing Panel 3	29	Heating Outlet
6	Cover Panel 2	18	3-way Valve	30	DHW Outlet
7	Coded Lock	19	Hinge	31	Hp Water Inlet
8	PCB Install Panel	20	Top Cover Panel	32	Rubber Cap (with 2 sizes)
9	Power Terminal	21	Safety Fixing Panel	33	Sealing Gasket (with 2 sizes)
10	PCB	22	Install Fixing Panel	34	Fixing Panel (with 2 sizes)
11	Electrical Box	23	Enclosure Panel		
12	Back-up Heater	24	DHW Inlet		

Control Module

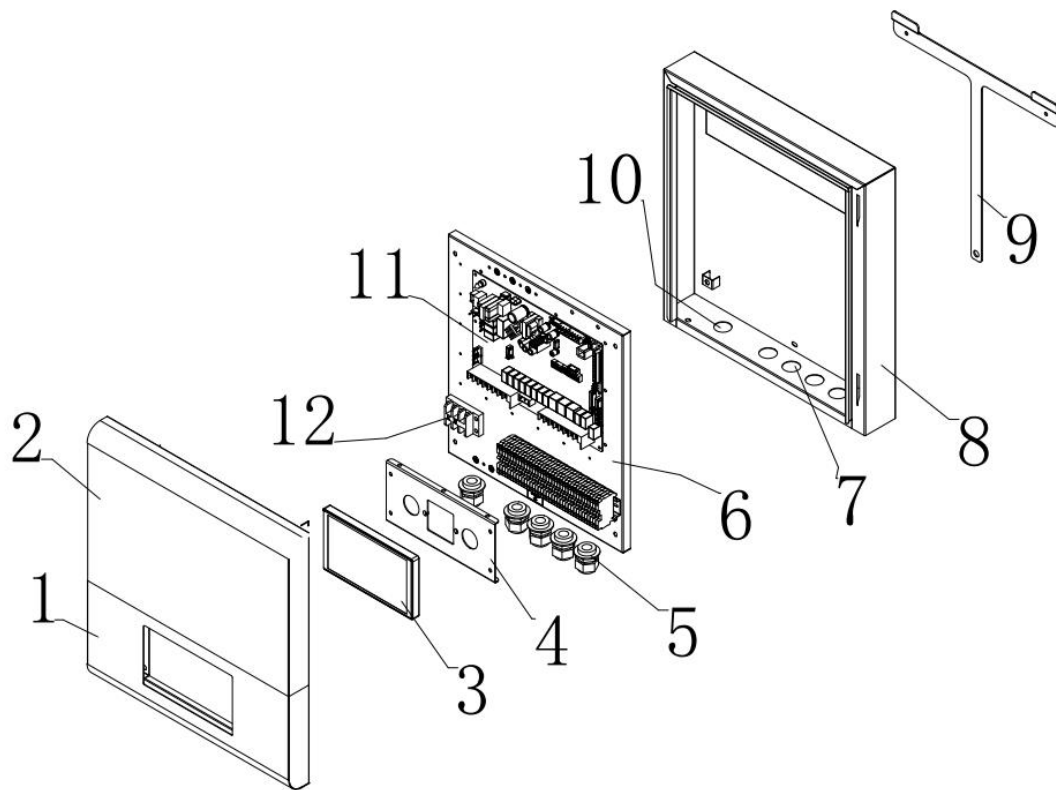

1	Front Panel 1	5	Cable Plug	9	Install Fixing Panel
2	Front Panel 2	6	PCB Install Panel	10	Power Cable Hole
3	Wire Controller	7	Control Cable Holes	11	PCB
4	Fixing Panel	8	Electrical Box	12	Power Terminal

DHW Hydraulic Module

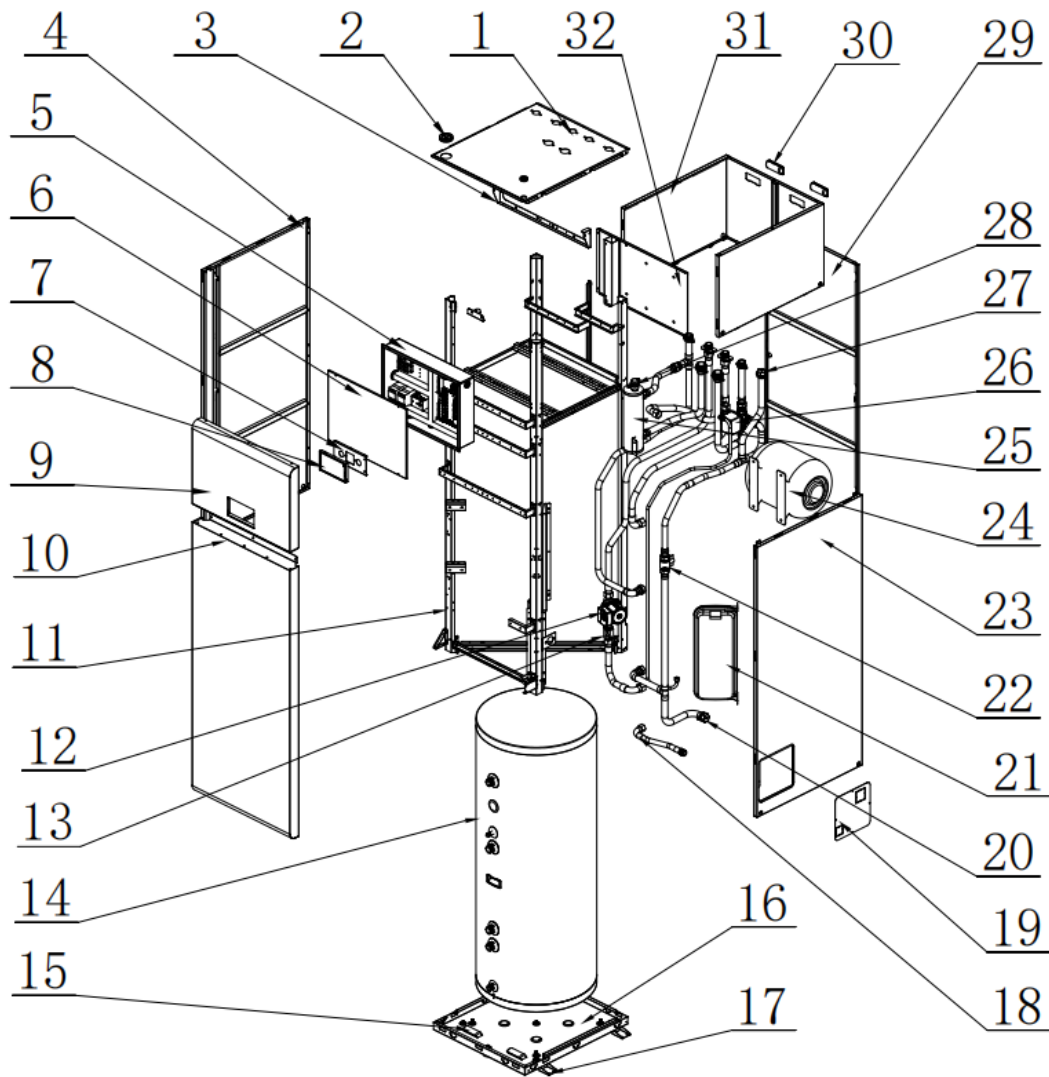

1	Top Cover	12	Water Pump	23	Right Panel
2	Cable Port	13	Ball Valve 1	24	Expansion Tank (DHW)
3	Fixing Panel 1	14	Hot Water Tank	25	Back-up Heater
4	Left Panel	15	Handle 1	26	3-Way Valve
5	Electrical Box	16	Chassis	27	Hydrating Port
6	Cover Panel	17	Fixing Panel 3	28	Exhaust Valve
7	Fixing Panel 2	18	Sewage Pipe	29	Back Panel
8	Wire Controller	19	Fixing Panel 4	30	Handle 2
9	Upper Front Panel	20	Drainage Outlet	31	Enclosure Panel
10	Lower Front Panel	21	Expansion Tank (Heating)	32	Middle Partition
11	Sheet Metal Frame	22	Ball Valve 2		

1.3. INSTALLATION AND CONNECTION

1.3.1. Installation

1. The internal unit needs to be wall mounted(except the DHW Hydraulic Module).

Installation procedure:

- ① First cut a hole in the wall according to the drilling diagram for the internal unit, which can be assisted by the Wall Mounting Plate supplied with the unit.
- ② Fix the Wall Mounting Plate to the wall using screws. It is important to ensure that the Wall Mounting Plate is level with the floor.
- ③ Hang the wall plate of the unit on the Wall Mounting Plate.

As shown in the diagram.

Hydraulic Module

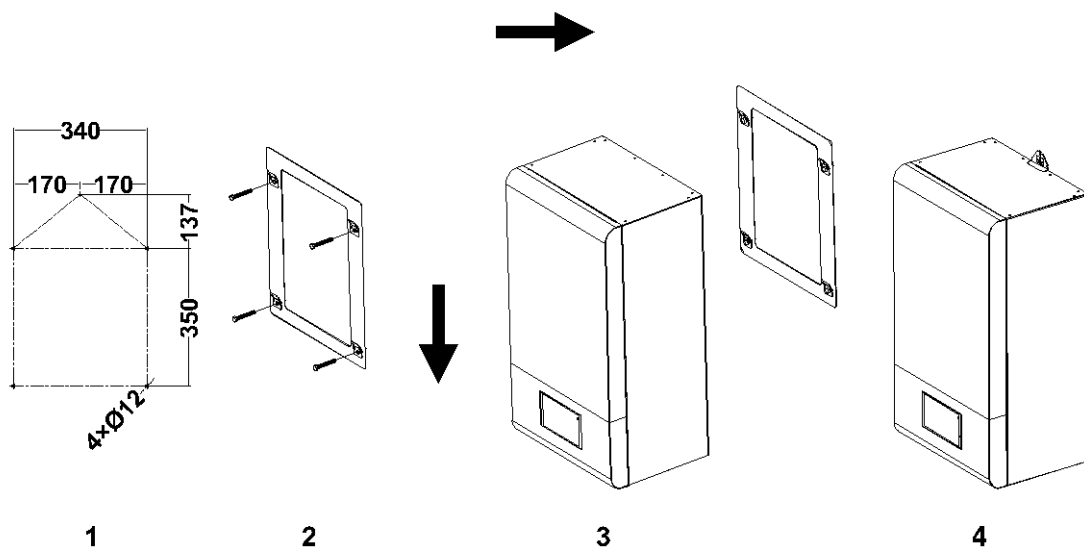

Control Module

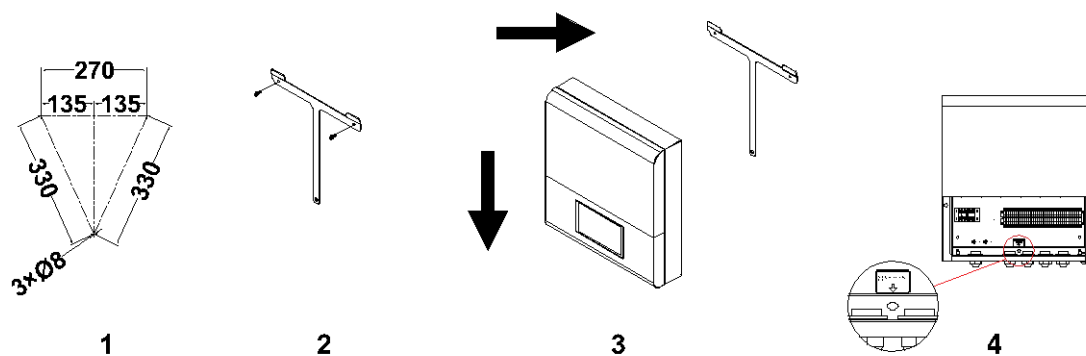

1. When the unit is mounted on the wall, the top fixing holes need to be installed in place at the same time to fix the unit when it is hung on the wall to prevent the unit from moving upwards for other reasons and thus falling off.

2. The water inlet and outlet of the indoor unit is recommended to be pre-installed with a ball valve, not a gate valve, in order to facilitate removability for later maintenance.

3. The auxiliary electric heating of the indoor unit is equipped with a high temperature protection function, which automatically cuts off the electric heating circuit when high temperatures are detected. This circuit breaker needs to be removed from the indoor unit panel and then manually reset the circuit breaker after it has been put into protection.

Please ensure that the water pump is working properly during operation to avoid overloading of the electric heating due to poor water circuit.

4. When the unit is wall mounted, please ensure the level of the unit to prevent the unit from tilting and causing other problems

DHW Hydraulic Module

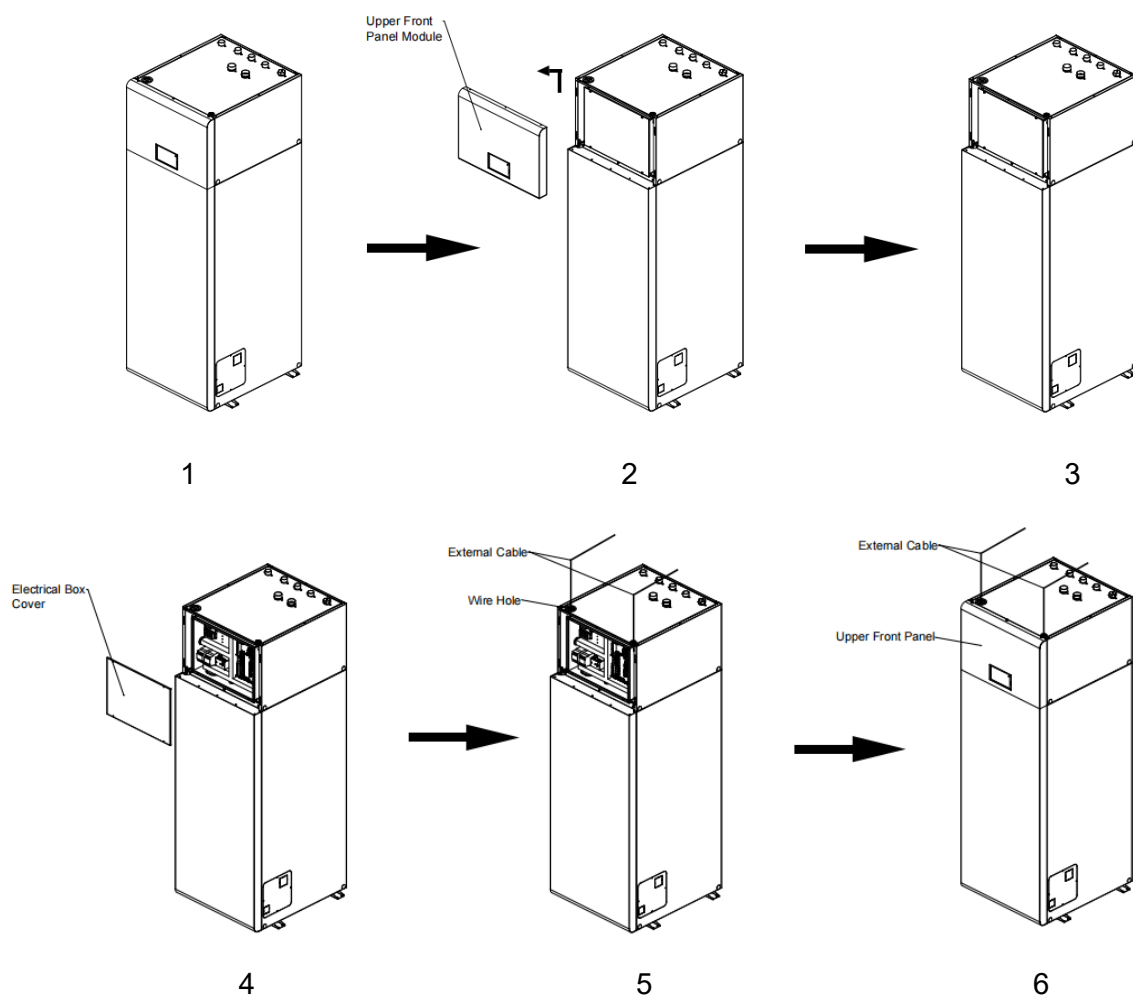

1. Remove the front panel module.
2. Remove the four pcs of M5 fixing screws on the front of the unit's electrical control box. Then remove this cover.
3. Pass the external cable through the cable hole and connect them to the electric control box.
4. After the external cable is connected and can operate normally, connect the above. Reverse the steps once to make the unit status complete.

1.3.2. Before Wiring

WARNING

- The main switch or other disconnecting switch components with separate connection points on all branch lines must be incorporated into the prescribed electrical wiring in accordance with the relevant local laws and regulations.
- Switch off the power supply before making any connections.
- Only copper wire may be used.
- Do not squeeze the bundled wires and ensure that they do not come into contact with pipes and sharp edges.
- Ensure that no external pressure is applied to the terminal connections.
- All field wiring and components must be installed by a licensed electrician and must comply with relevant local laws and regulations.
- Field wiring must be carried out in accordance with the wiring diagram supplied with the appliance and the instructions given below.

Always use a dedicated power supply. Do not use a power source shared by other devices.

- Always build a foundation. Do not ground the equipment to a utility pipe, surge protector or telephone ground. Incomplete grounding may result in electric shock.

Always install an earth fault circuit breaker (30 mA). Failure to do so may result in electric shock.

- Be sure to install the required fuses or circuit breakers.

Precautions before installation

- Secure the wires so that they do not come into contact with the pipes (especially the high pressure side)
- Secure the wires with cable ties as shown in the diagram so that they do not touch the pipe, especially the high pressure side.
- Ensure that no external pressure is applied to the terminal connector.

- When installing the earth fault circuit breaker, ensure that it is compatible with the inverter (resistant to high frequency air noise) to avoid unnecessary opening of the earth fault circuit breaker.

1.3.3. Electrical Connection

The ground fault circuit breaker must be a 30 mA (<0.1 s), high-speed type.

Please use a cable of the correct number of cores and size.

Current ratings are based on the maximum permissible operating temperature of the conductor (105°C/70°C) and in the rated ambient temperature (40°C/25°C) and assuming free separation in air for a single wire, with wire diameter cross-references, as shown in the table below.

Maximum operating current of the unit (A)	Cross-sectional area of conductors (AWG)	Maximum operating current of the unit (A)	Cross-sectional area of conductors (AWG)
≤3.0	≥24	≤15	≥14
≤4.6	≥22	≤21	≥12
≤6.5	≥20	≤28	≥10
≤8.5	≥18	≤40	≥8
≤11	≥16	≤55	≥6

- Use the H07RN-F power cord with all wires connected to the high voltage side except for the thermistor cable and the user connector cable.
The equipment must be earthed.
- All high-voltage external loads must be earthed if they are metallic or earthed outlets.
- All external load currents must be less than 0.2 A. If individual load currents are greater than 0.2 A, the load must be controlled via an AC contactor.
- Terminals "AHS1, AHS2", "DFR1, DFR2" and "ERR1, ERR2" provide only switching signals.
- The terminal block of "DI2, G" and "SG, EVU, G" terminal receives the switch signal.

Please refer to the diagram below for the location of the ports in the device.

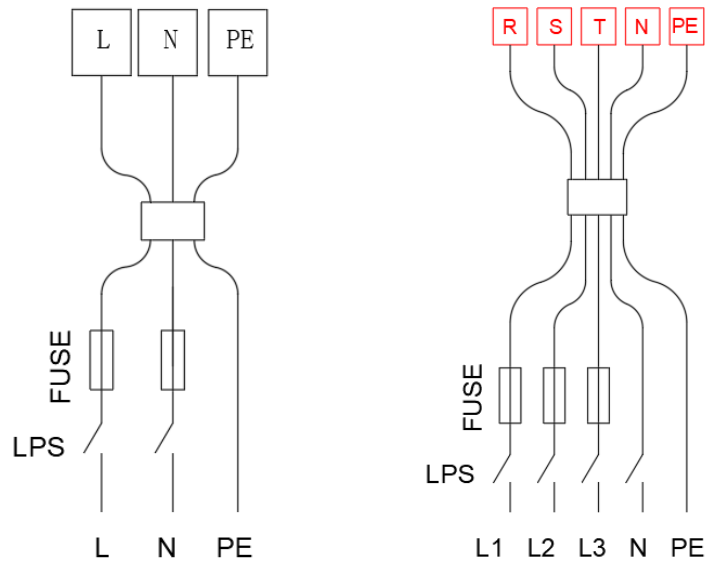

1. Customer Installation Wiring Section

① Open the handle on the right side of the unit

② Wiring Section

You can use the communication cable to connect the outdoor heat pump with indoor control module or hydraulic module as shown below.

Power Supply:

230V~50Hz

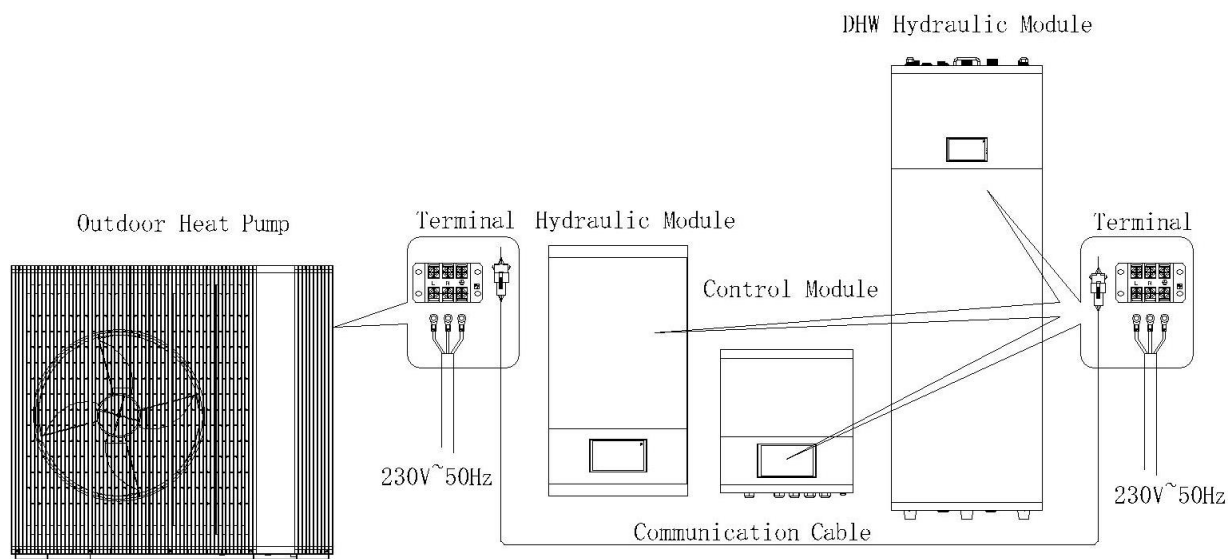

380V 3N~50Hz

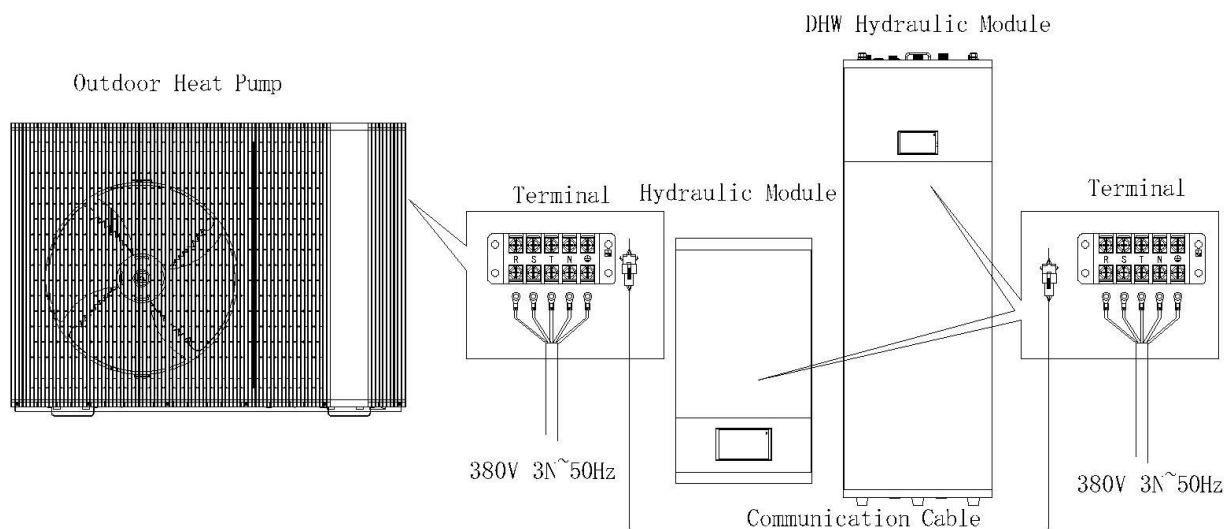

1.3.3.1. Customer installation wiring section

① Open the the customer wiring section

1. Front panel removal: Remove the 4 screws at the bottom of the indoor unit, then push the front panel upwards.

2. Removal of the customer wiring section cover: After removing the front panel, remove the 4 screws on the cover to take it off.

3. Customer wiring section

② Wiring Section

380V~/3N~/50Hz:

1.3.3.2. Assembly connection

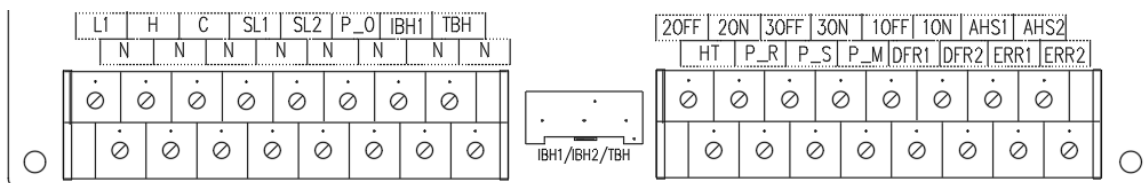

Print	Connect to	Print	Connect to
20FF	2# Three-Way Valve (Heating Direction)	AHS1	External Heat Source
20N	2# Three-Way Valve (Cooling Direction)	AHS2	
30FF	3# Three-Way Valve (Open Circulation)	DFR1	Defrost Indication
30N	3# Three-Way Valve (Close Circulation)	DFR2	
10FF	1# Three-Way Valve (DHW Direction)	ERR1	Fault Indication
10N	1# Three-Way Valve (H&C Direction)	ERR2	
HT	Anti-freeze Electric Heater Belts	SL1	Solar Signal
P_R	Lower Return Water Pump	SL2	
P_S	Solar Pump	DI2	Display Switch
P_M	Mixing Water Pump	G	
H-L1	Thermostat (H Signal)	SG-G	Smart Grid (SG)
C-L1	Thermostat (C Signal)	EVU-G	Smart Grid (EVU)
P_O	Outside Circulation Pump	TBH	Electric Heater for Water Tank

Function instructions:

1. Output.

Control method.

Type 1: Dry-type connector with no voltage.

Type 2: Socket provides signal for 220V. If the load current is <0.2A, the load can be connected directly to the socket.

If the load current $\geq 0.2A$, an AC contactor needs to be connected to the load.

1.3.3.2.1. For three-way valve

When installing the water circuit, please use a three-wire, two-control 3-way valve, the wiring schematic for the 3-way valve is shown in the following diagram.

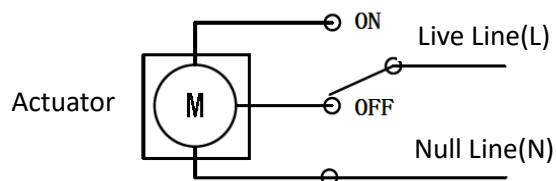

Three-way valve wiring specifications are shown in the following diagram.

Power Supply	220-240VAC
Max. Current	0.2A
Wire Specifications	20AWG/0.75mm ²
Control Method	Type 2

2# Solenoid 3-way valve wiring

2# solenoid three-way valve is used to switch the air-conditioning heating and cooling water circuit, and the control line of the three-way valve needs to be connected to the corresponding point on the terminal block of the unit during construction and installation. When the air conditioner is running, there is 220V output at the 2OFF connection point and no output at the 2ON point; when the unit is running, there is 220V output at the 2ON point and no output at the 2OFF point. When wiring, you need to confirm the various water connections of the solenoid 3-way valve to ensure that the 3-way valve is switched to the correct water circuit when the unit is in operation.

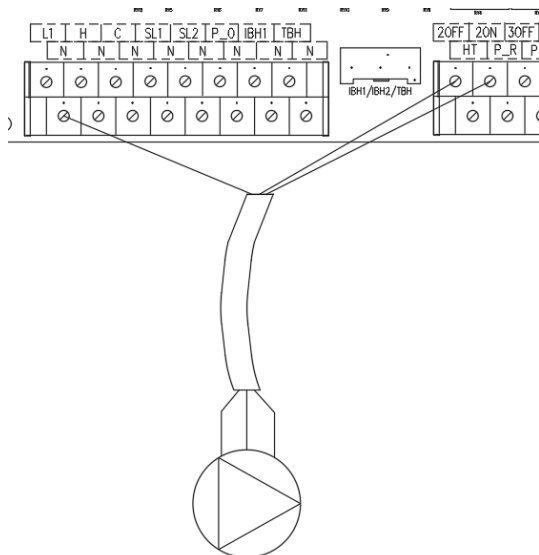

2#Electromagnetic 3-way valve

3# Solenoid 3-way valve wiring

The 3# solenoid 3-way valve is used to control whether the water in the balance tank enters the underfloor heating water circuit in Zone B. When the floor heating water temperature is

too high, the three-way valve switches direction, at this time the floor heating water circuit circulates in the floor heating pipe, the hot water in the balance tank does not enter the floor heating, the 3ON point keeps 220V output, the 3OFF point has no output; when the floor heating water temperature is too low, the three-way valve switches direction and the hot water in the balance tank enters the B area floor heating, at this time the 3OFF point keeps 220V output, the 3ON point has no output.

When wiring, you need to confirm the individual water connections of the solenoid 3-way valve to ensure that the 3-way valve switches to the correct water circuit when the unit is in operation.

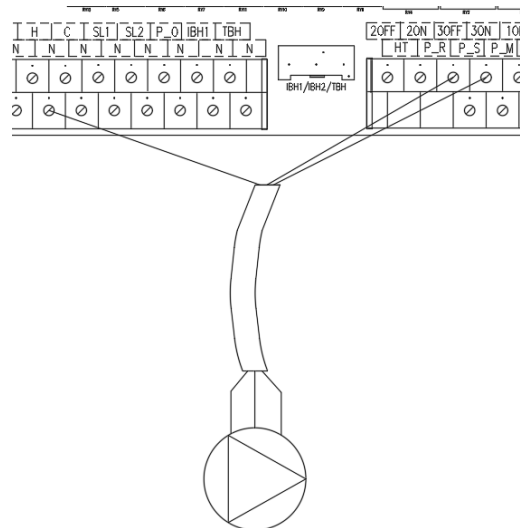

3#Electromagnetic 3-way valve

Power Supply	220-240VAC
Max. Current	0.2A
Wire Specifications	20AWG/0.75mm ²
Control Method	Type 2

1.3.3.2.2. For water pump

Lower return water pump

1.3.3.2.3. For electric heater

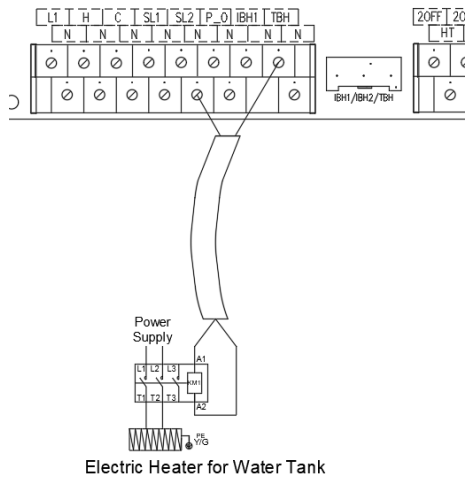

Power Supply	220-240VAC
Max. Current	0.2A
Wire Specifications	20AWG/0.75mm ²
Control Method	Type 2

1.3.3.2.4. For thermostat

The "Power Supply In" provides the voltage for the "Thermostat" and does not supply power directly to the motherboard interface. Port "L1" supplies 220V to the RT connector. Outlet "L1" is connected to the single-phase power supply from the unit's mains outlet L.

There are three ways of connecting the thermostat cable (as described in the diagram above), depending on the application.

Method 1: When "Thermostat Control" is set to "Single Zone Mode Switching".

- (a) When signal C is closed, zone A is switched on for cooling operation.
- (a) When the C signal is off and the H signal is closed, zone A is switched on for heating operation.
- (a) Zone A is closed when both the C signal and the H signal are disconnected.

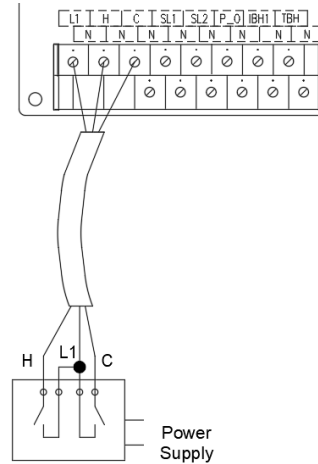

Method 2, When "Thermostat Control" is set to "Single Zone Switch".

- (a) Zone A is opened when signal C is closed.
- (a) Zone A is closed when the C signal is disconnected.

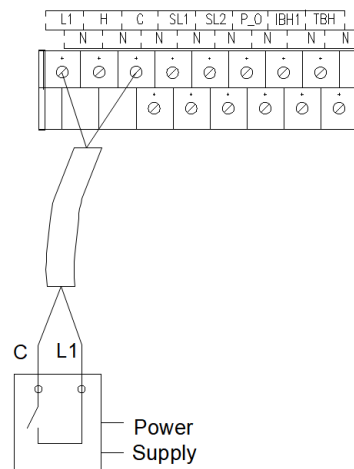

Method 3: When "Thermostat Control" is set to "Dual Zone Switching".

Zone A opens when signal C is closed; zone A closes when signal C is broken.

Zone B opens when the H signal is closed; zone B closes when the H signal is broken.

Note: Zone B is for heating operation only

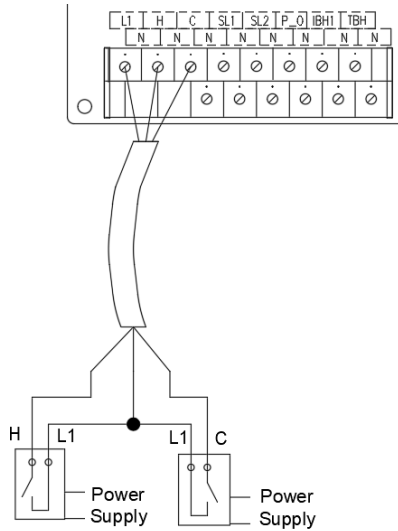

Power Supply	220-240VAC
Max. Current	0.2A
Wire Specifications	20AWG/0.75mm ²

1.3.3.2.5. For signal output and external heat source

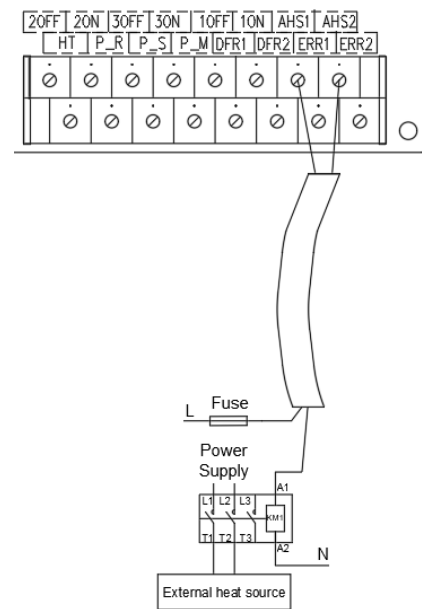
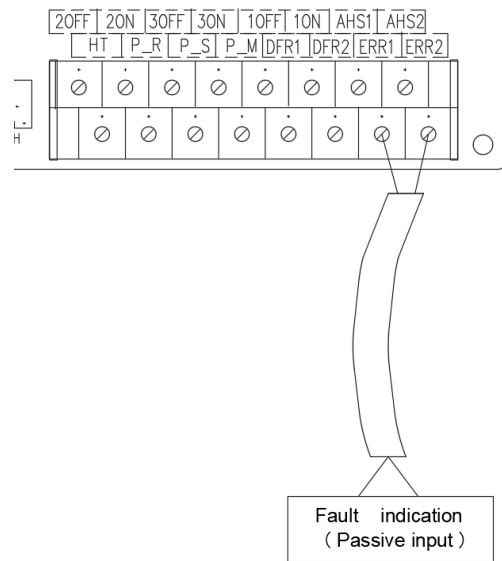
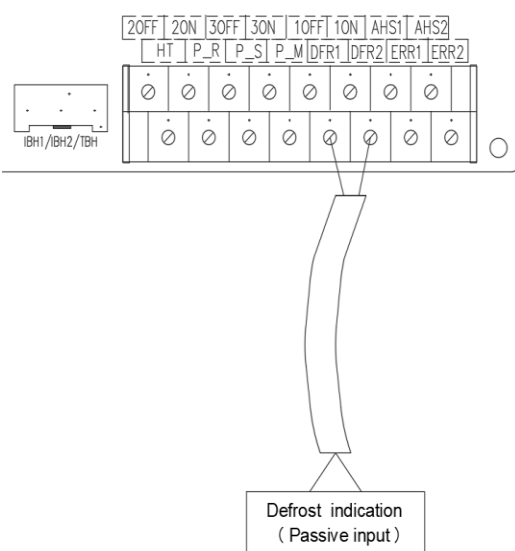

Power Supply	220-240VAC
Max. Current	0.2A
Wire Specifications	20AWG/0.75mm ²
Control Method	Type 1

1.3.3.2.6. For wire controller switch

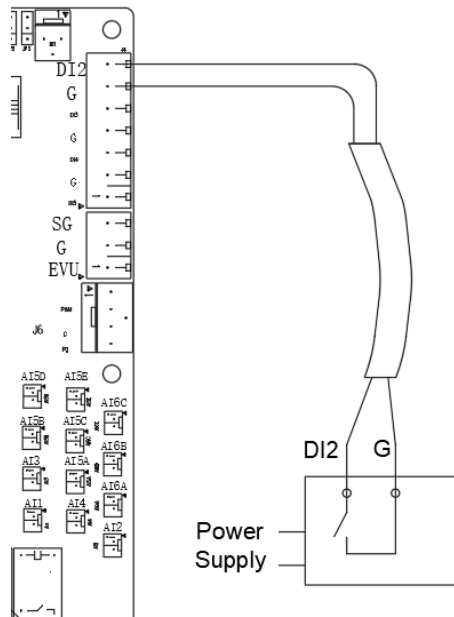

1.3.3.2.7. For smart grid

The smart grid wiring is shown in the diagram below, SG is the smart grid signal and EVU is the PV signal

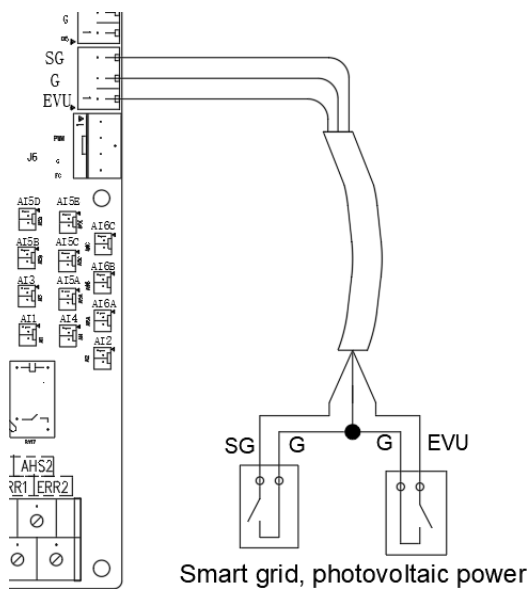

1.3.3.2.8. For solar signal

(220V power input, L and N)

When the [Solar Temperature Sensor] is set to "Disable", you need to access the solar signal to control the solar water pump start and stop, the wiring is shown in the diagram below

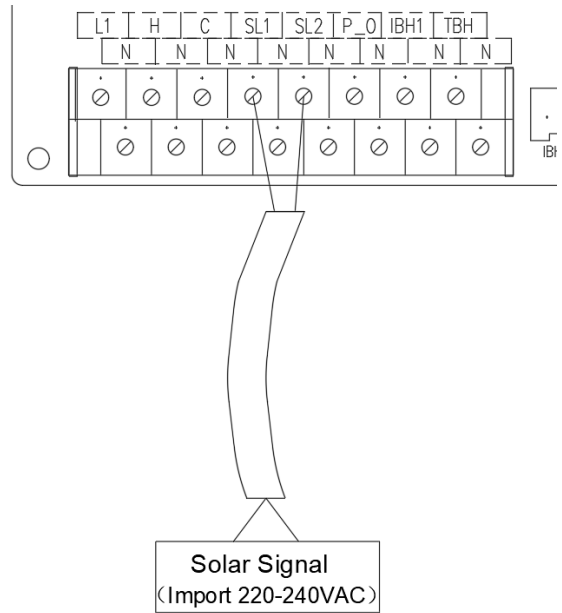

2. CONTROLLER OPERATION

2.1. GENERAL SAFETY PRECAUTIONS

2.1.1. About The Documentation

The precautions described in this document cover very important topics, follow them carefully. All activities described in the installation manual must be performed by an authorized installer.



- **WARNING:**Indicates a situation that could result in death or serious injury.
- **CAUTION:**Indicates a situation that could result in minor or moderate injury.
- **DANGER:**Indicates a situation that results in death or serious injury.
- **DANGER: RISK OF ELECTROCUTION:**Indicates a situation that could result in electrocution.
- **DANGER: RISK OF BURNING:**Indicates a situation that could result in burning because of extreme hot or cold temperatures.
- **NOTE:**Indicates a situation that could result in equipment or property damage.
- **INFORMATION:**Indicates useful tips or additional information.

2.1.2. For The User

- If you are not sure how to operate the unit, contact your installer.
- The appliance is not intended for use by persons, including children, with reduced physical, sensory or mental capabilities, or lack of experience and knowledge, unless they have been given supervision or instruction concerning use of the appliance by a person responsible for their safety. Children must be supervised to ensure that they do not play with the product.
- Unit are marked with the following symbol:
This means that electrical and electronic products cannot be mixed with unsorted household waste. **Do NOT** try to dismantle the system yourself: the dismantling of the system, treatment of the refrigerant, of oil and of other parts must be done by an authorized installer and must comply with applicable legislation. Units must be treated at a specialized treatment facility for reuse, recycling and recovery. By ensuring this product is disposed of correctly, you will help to prevent potential negative consequences for the environment and human health. For more information, contact your installer or local authority.
- Placed in a location away from radiation.

2.2. Power On Interface

2.2.1. The Appearance of The Wired Controller

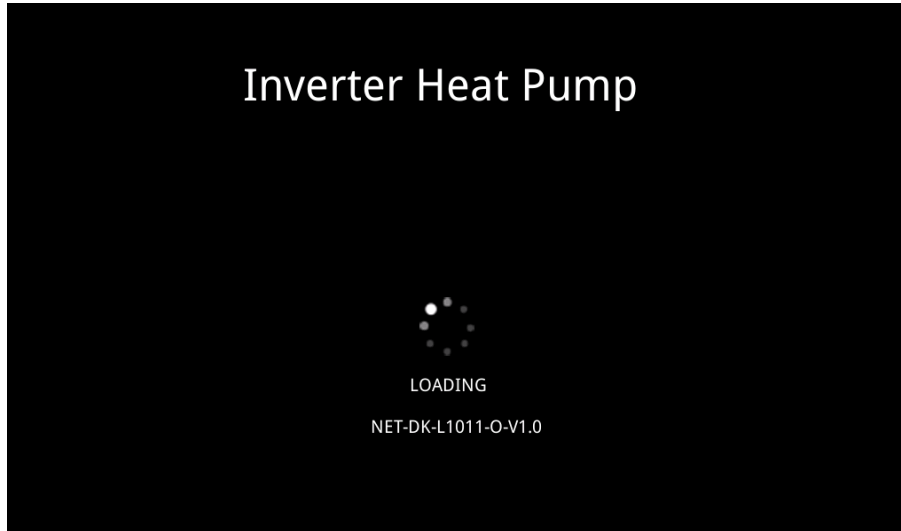



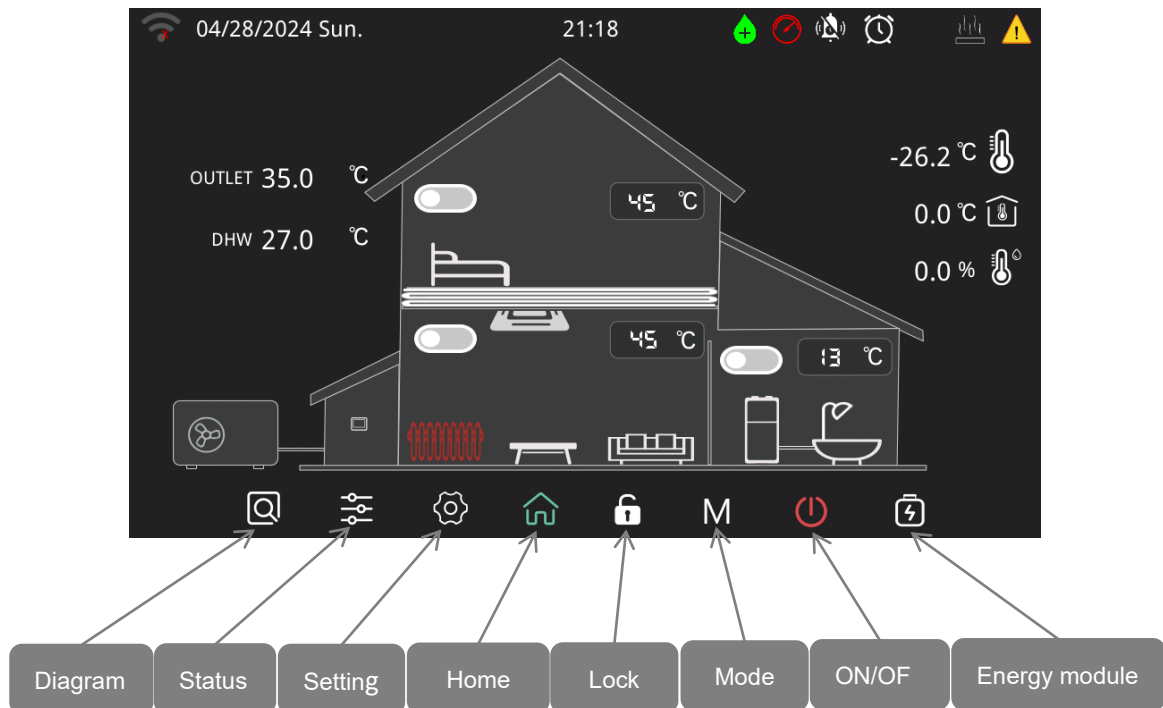

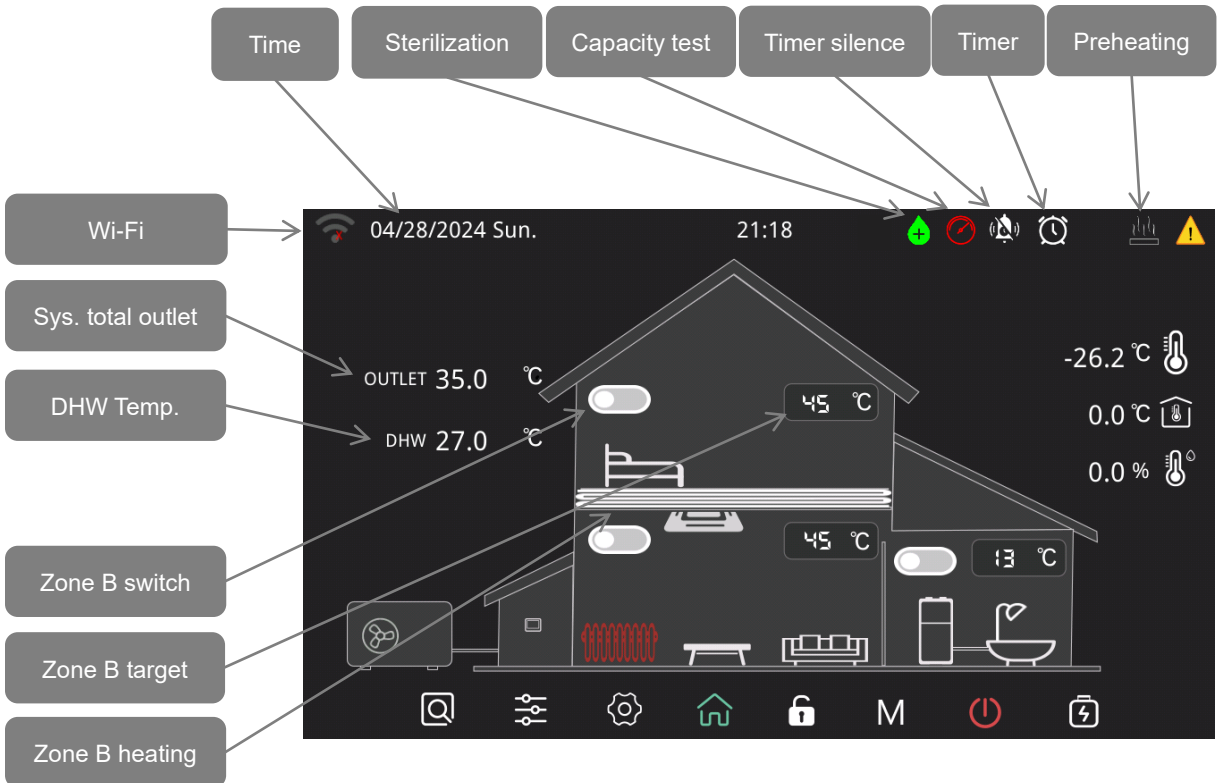
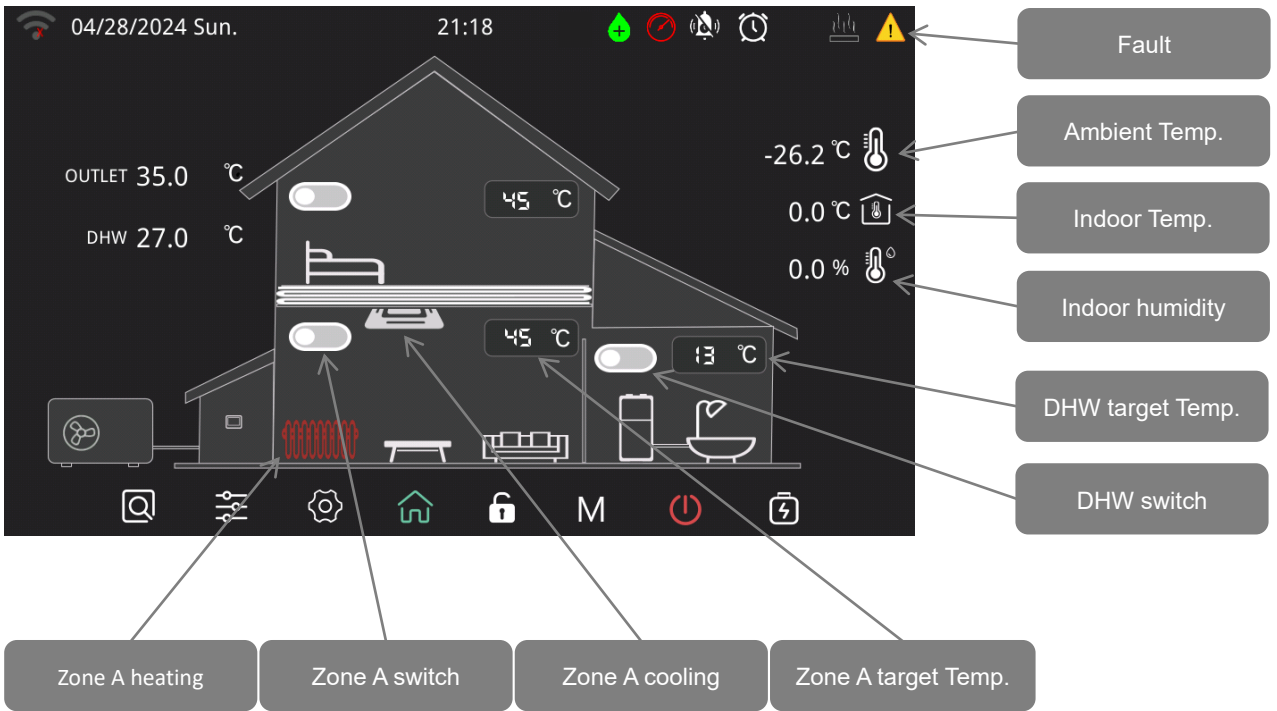



















When powering on for the first time, after staying in the dynamic interface for 20 seconds, enter the following main interface according to the motherboard mode.





2.2.2. Status Icons

Icons	Status	Description	Icons	Status	Description
	Network status	Always on indicates networking		Defrosting	Unit currently operating defrost function
	Network status	Flashing display distribution network		Anti-frost	Unit is currently operating with anti-freeze function
	Hot water mode	Dynamically indicates power on		Holiday	Unit currently running in holiday mode
	Underfloor heating	Dynamically indicates power on		Quiet	The unit is currently running in silent mode
	Fault	Unit is faulty		Energy saving	The unit is currently running in energy saving mode
	Preheating	Blinking indicates preheating		Capacity test	Unit currently running capacity test
	Timer silence	The wire controller turns on the timed mute		Fluoride collection	Unit currently running fluoride collection function
	Timer function	The wire controller turns on the timed function		Antibacterial	Unit currently running sterilization function
	External heat source	External heat source output		Smart grid configuration 1	Smart grid configuration 1 activated
	Solar signal	Solar signal input		Smart grid configuration 2	Smart grid configuration 2 activated
	Water tank electric heater	Water tank electric heater output		Smart grid configuration 3	Smart grid configuration 3 activated
	Auxiliary electric heater	Auxiliary electric heater output		Smart grid configuration 4	Smart grid configuration 4 activated

2.3. WIRE CONTROLLER OPERATION GUIDANCE

2.3.1. Single/Double Zone

In the OFF state, Slide left on the main page - click "General" - click "Parameter" - enter password " 168" - click "N Parameters" -Scroll to page 3 and click on N26 to select single and double zone mode.



	Para.M	Para.N	Para.G	Para.P
N20	DHW Tank Electric Heater			Disable
N21	DHW Return Water Pump			Disable
N22	Solar Heater			Disable
N23	Linkage Switch Setting			0
N26	Wire Controller Control Type			2
N27	Load Correction Amplitude			44 °C
N32	Smart Grid			Disable

2.3.2. No Hot Water in Single Zone A

a) When the unit is in off state, short press the "  " switch button to turn on the unit.

b) The dynamic display of the mode icon means the compressor is on, and the static display means the compressor is off.

c) Without the hot water function, the hot water target temperature is not displayed.





(Note: ON means zone A is on, OFF means zone A is off.)

2.3.3. Single Zone A + Hot Water

a) When the unit is in the off state (zone A and



hot water are in the off state), short press the "  " total on/off button, and all the zone A and hot water functions will be turned on.

b) When the zone A is in the off state, click the "  " zone A switch button, and the zone A will be turned on.

c) Hot water in the off state, click "  " hot water switch button, hot water on.

d)The dynamic display of the mode icon means the compressor is on, and the static display means the compressor is off.

e) With hot water function, the target temperature of hot water is displayed.

(Note: "  " stands for on, "  " stands for off)



2.3.4. No Hot Water in Double Zone

a) When the unit is in the off state (both zone A and zone B are in the off state), short press the "  " total on/off button, zone A and zone B will all be turned on.

b) When the A zone is in the off state, click the "  " zone A switch button, and the zone A will be turned on.

c) zone B is in the off state, click the "  " zone B switch button, and the zone B will be turned on.

zone B switch button, zone B power on.

d) zone A is in cooling mode, zone B (floor heating) can not be turned on.

e)The dynamic display of the mode icon means the compressor is on, and the static display means the compressor is off.

f) No hot water function, does not display the target temperature of hot water.

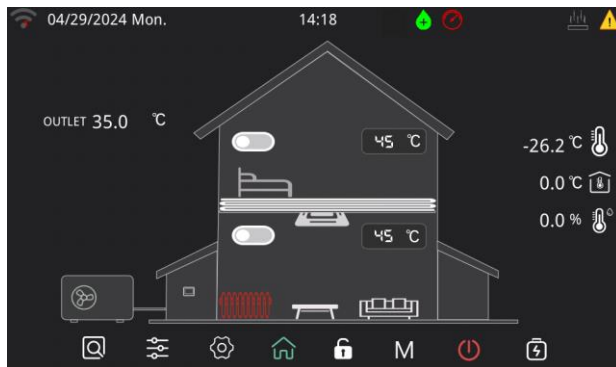

2.3.5. Double Zone + Hot Water

a) When the unit is in the off state (both zone A and zone B are in the off state), short press the "  " total on/off button, zone A and zone B will all be turned on.

b) When the zone A is in the off state, click the "  " zone A switch button, and the zone A will be turned on.

c) zone B is in the off state, click the "  " zone B switch button, zone B on.

d) zone A is in cooling mode, zone B (floor heating) can not be turned on.

e) Mode icon dynamically displayed on behalf of compressor on, static means the compressor off.

f) The dynamic display of the mode icon means the compressor is on, and the static display

means the compressor is off.

g)With hot water function, target temperature of hot water is displayed.

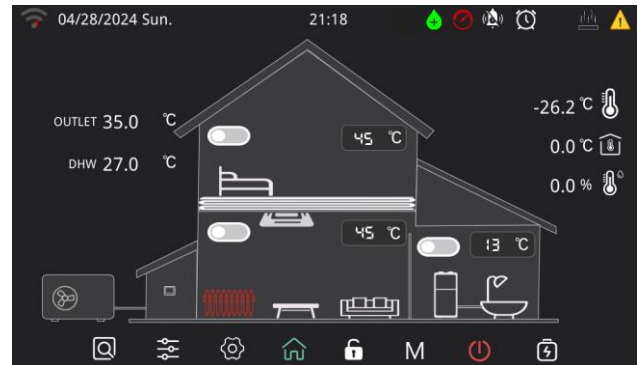

2.3.6. Lock/Unlock Function

At the main interface, press "  " to lock/unlock.

2.3.7. Setting Mode

At the main interface, short press "  " mode key to jump to the corresponding interface according to the current mode supported by the unit.

For example, when the unit supports cooling and heating modes, short press the "  " mode key to enter the mode setting:

cooling, heating, automatic.

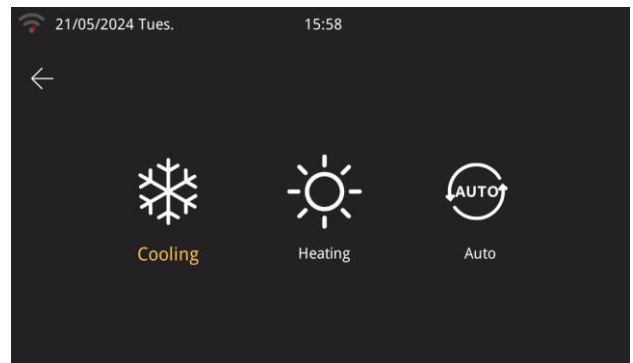

Note: Enter the password "168" in "Parameter" and set the heating & cooling type by modifying N02.

2.3.8. Setting Target Temperature

According to the main page display mode status setting, click on the target temperature to set the desired target temperature.

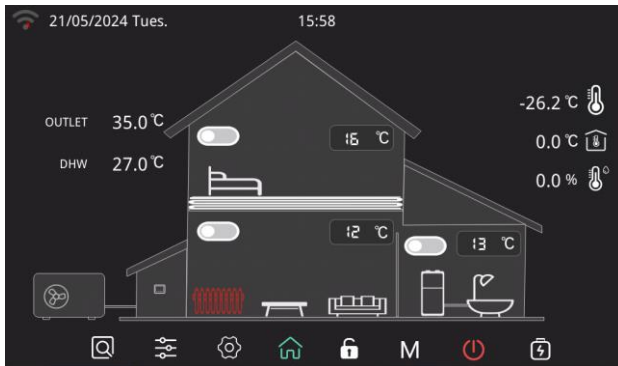

2.3.9. Screen Saver / Screen Off

1) Turn on the screen saver

In all interfaces, for 60s without touching the screen, the screen brightness will automatically drop to 20% brightness, for 6min without touching the screen, the wire controller automatically jump to the screensaver interface, for 8min without touching the screen, the wire controller into a hibernation state.

Hibernation state, click on the screen wire controller bright screen display is still screensaver interface (only bright screen does not perform other actions).

The brightness of the controller 20% state: click on the screen controller brightness increased to 100% (Only bright screen does not perform other actions, and does not switch the interface.)

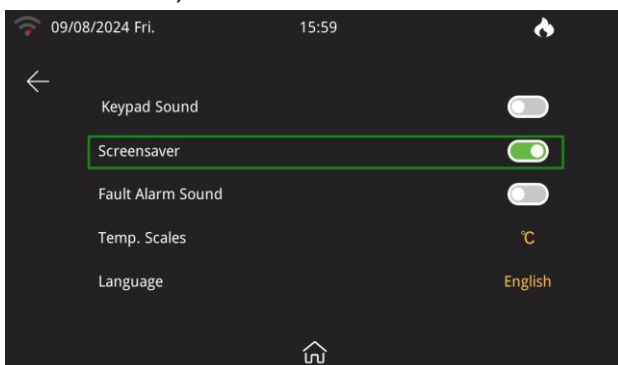

2) Turn off the screen saver function

In all interfaces, for 60s without touching the

screen, the screen brightness will automatically drop to 20% brightness, for 6min without touching the screen, the wire controller into the hibernation state.

hibernation state, click on the screen controller bright screen display back to the main interface (Only bright screen does not perform other actions).

The brightness of the controller is 20%: click on the screen to increase the brightness of the controller to 100% (Only bright screen does not perform other actions, and does not switch the interface).

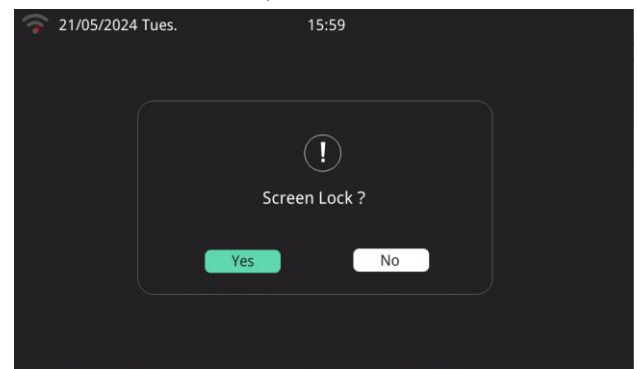

2.3.10. Fault Display

When the unit has a fault, the main interface fault icon flashes, click "!" to check the fault content of the current unit.

Click " Fault Reset" to reset the fault.

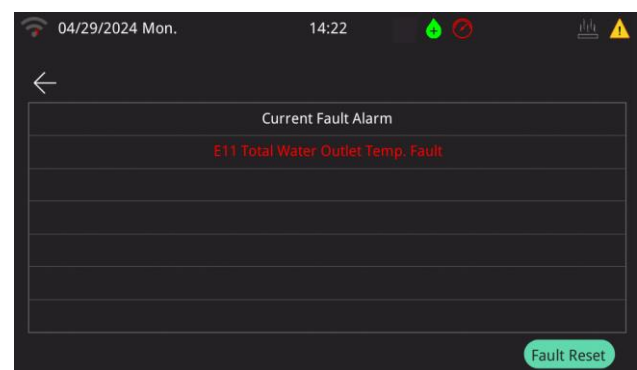

2.3.11. Check Parameter Status

At the main interface, swipe from left to right to view the current operating status.

(When the temperature sensor fails, "-.-" will be displayed on the screen.)

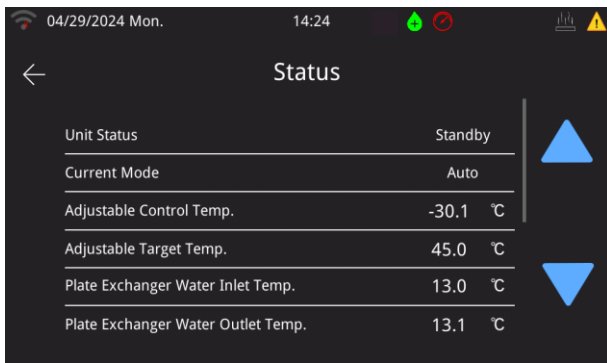

2.3.12. Parameter Setting Interface

At the main interface, swipe from right to left to view the settings interface.

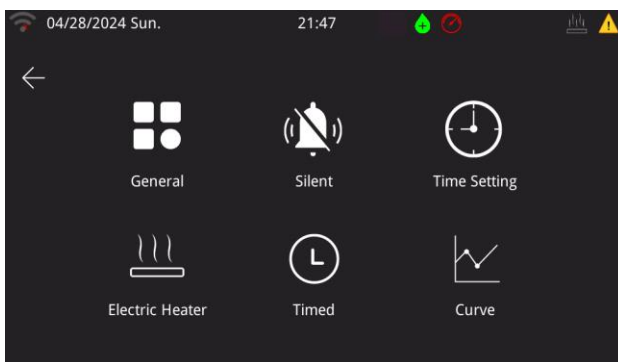

2.3.13. Setting Interface

At the setting interface, press “” to enter the system parameter interface.

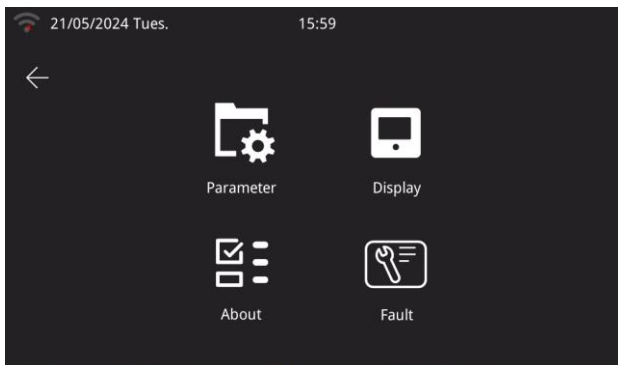

1) Customer Management Interface

a) At the system parameter interface, press

“” and input the password “400866” to enter the restore factory setting interface.

b) At the system parameter interface, press

“” and input the password “168” to enter the customer management interface.



● User parameter

Press “User Para” to set the user parameter.

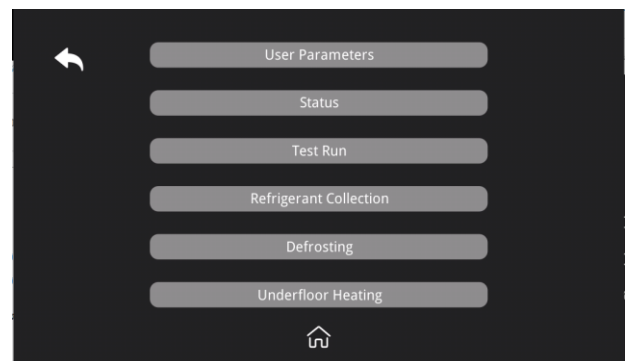

● Status

Press "Status" to view the system status of the unit.

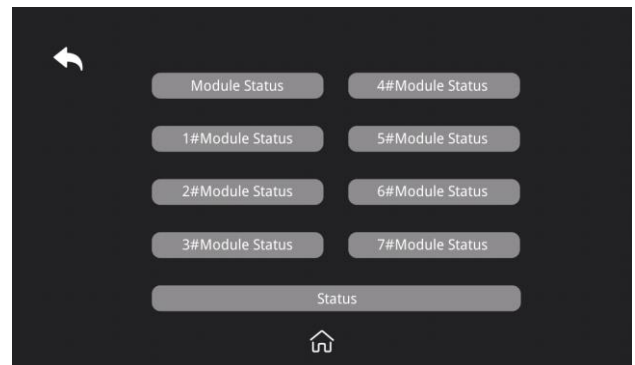

● Test run

Press "Test run" for test run of unit function.

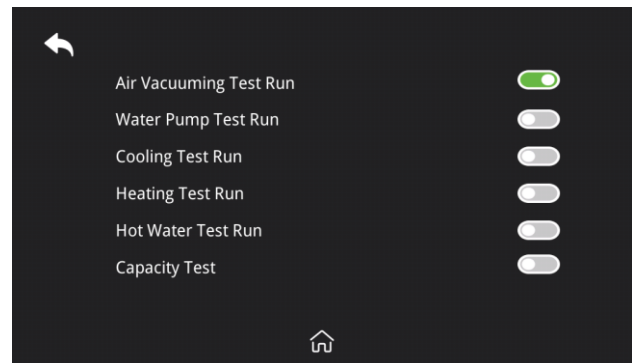

- **Manual Defrosting**



- Enter the Customer Parameters interface;
- Click on "Defrosting".
- Select the module to be defrosted by yourself.
(The content of the displayed modules is determined by the "Number of modules" parameter, e.g. if the number of modules is 2, the current number of defrosting modules can be set to 2.)

- **Underfloor Heating**

Press "Underfloor Heating" to set the floor heating preheat function.

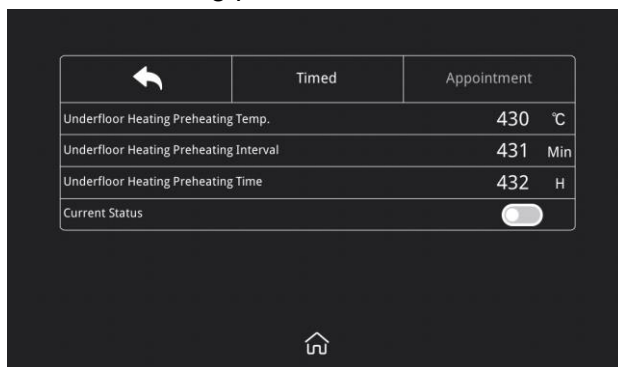

2) Display Interface

At the system parameter interface, press

“” to enter the display interface.

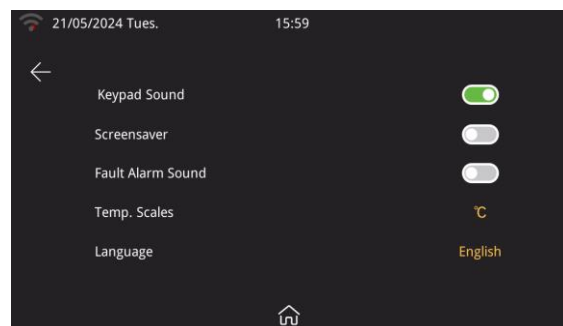

- **Key Sound**

- When sound is on: the buzzer sounds when the screen is tapped.
- When sound is off: the buzzer does not sound when the screen is tapped.

- **Screen Protection**

Details can be found in page 6.

- **Fault Alarm**

After it is turned on, when a fault occurs in the unit, the wired controller buzzes every 30 seconds until the fault is resolved.

- **Unit of Temp.**



Each time the temperature unit is switched, the wire controller enters the read parameter interface and re-reads all the advanced parameters, returning to the setting interface after 20s.

- **Switch Language**

Press "Switch Language" to switch the language.



3) Information Interface

At the system parameter interface, press

“” to enter the information interface.

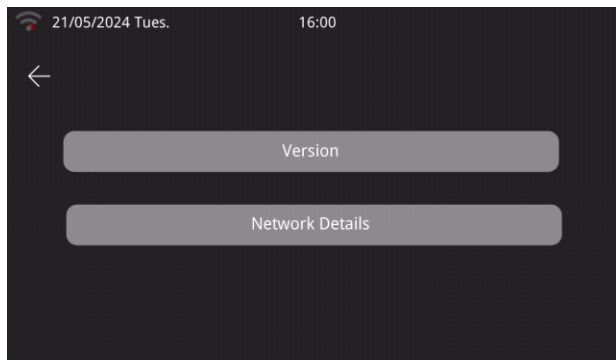

4) History Fault

At the system parameter interface, press

“” and then input “168” to enter the history fault interface.

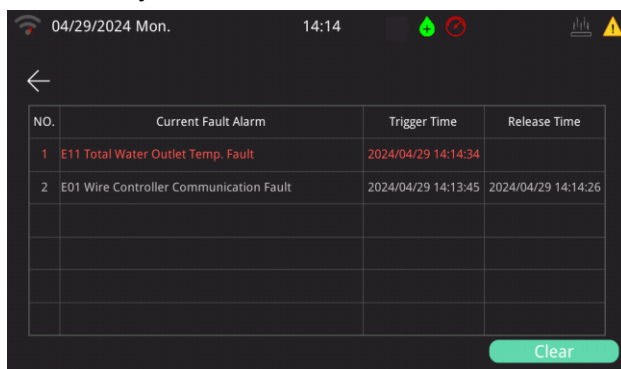

2.3.14. Curve

At the setting interface, press “” to enter the curve interface.

- Every 20min to collect temp. data, every 1h to save the data. If less than 1h, the data within this period will not be saved.
- The temp. curve is with power-down memory function.

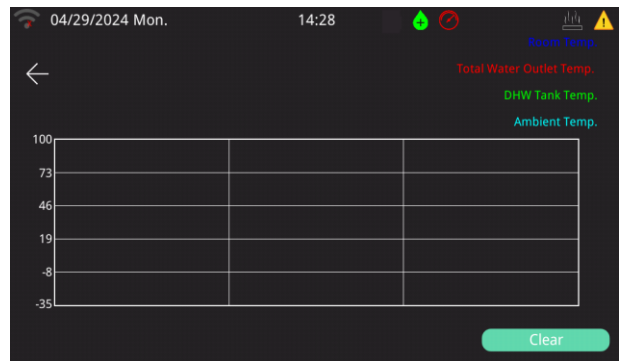

2.3.15. Time Setting

At the setting interface, press “” to enter the time setting interface.

While the unit is °C, the time setting page is as follows:

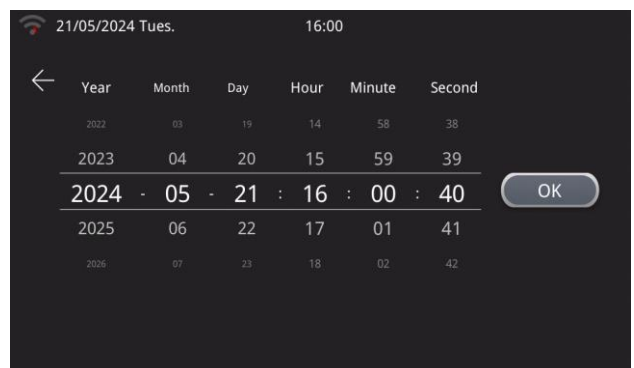

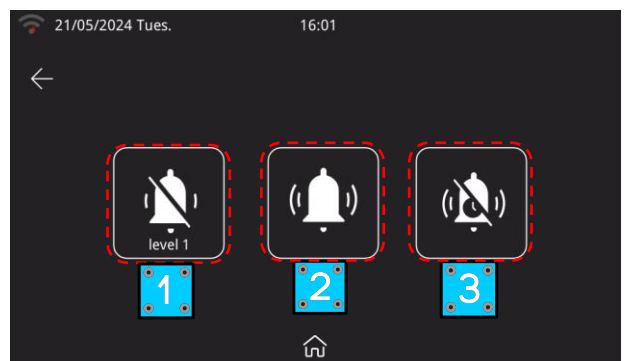

2.3.16. Manual Mute

In the settings screen, press “” enter the mute function .





1) Mute Level

 Level 1: Indicates that the unit is currently in the first level of silence.

 Level 2: Indicates that the unit is currently in secondary silence.

2) Mute Mode

: Indicates that the unit is not currently muted.

: Indicates that the unit is currently muted.

3) Timer Mute

Press "" to enter the timer mute setting interface.

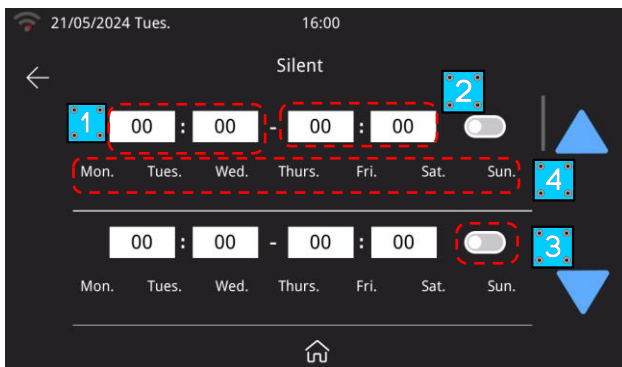

- ① Mute setting start time
- ② Mute setting end time
- ③ While the mute setting is valid, the background is green; While the mute setting is invalid, the background is gray.

④ Press MON~SUN to choose which day to be valid for the timer. The day will become red after pressing.

Note: If timed on time is equal to timed off time, the segment cannot take effect.

If timing is not on or the timing on week is not selected, the segment of timing cannot take effect.

If the timings are set to cross, the opening time or end time will be executed according to



the earliest time.

2.3.17. Timed Function

1) Timed ON/OFF Setting

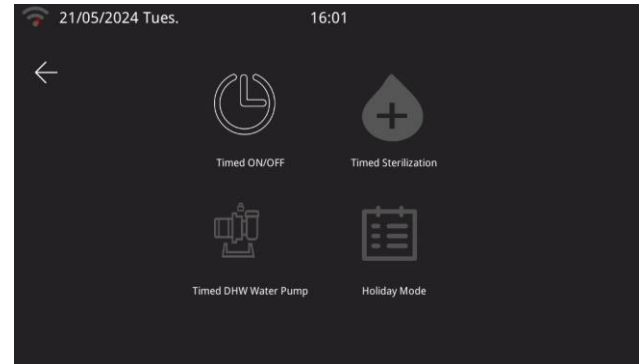
At the setting interface, click " " and then click "Timer Switch" to enter the Timer ON/OFF setting interface.



" " indicates that the timer switch function is on,"  " indicates that the

timer switch function is not on,"  " indicates that the unit does not have a timer on/off function.

Note: If timed on time is equal to timed off time, the segment cannot take effect.

If timing is not on or the timing on week is not selected, the segment of timing cannot take effect.

If the timings are set to cross, the opening time or end time will be executed according to the earliest time.

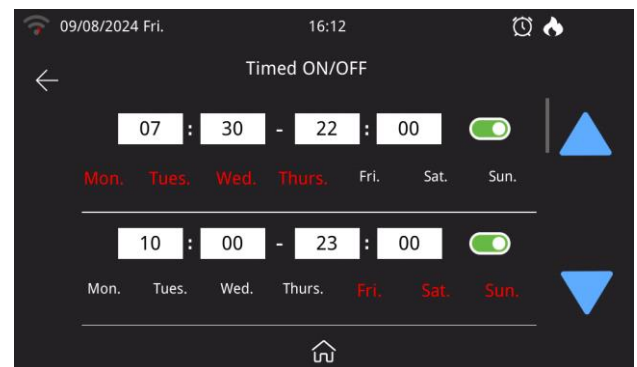

2) Timed Sterilization Function

At the setting interface, press "🕒" in the settings screen, then press "Timed Sterilization" Enter the timed sterilization function.

Click on the button to turn on the sterilization function (🟢 stands for sterilization on, ⚪ stands for sterilization off.)

For example, the sterilization function is on and the timer function is also in effect, which turns on at 10.30am on Sunday morning.

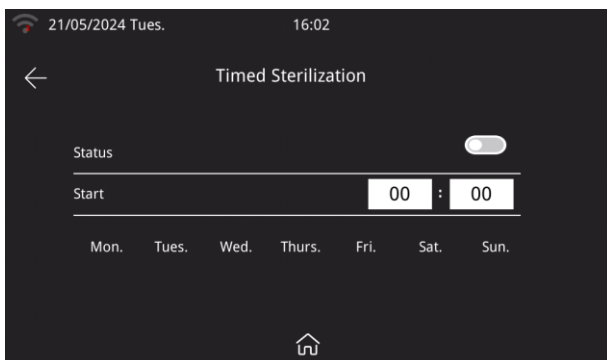

Operating conditions: Turn on sterilization parameters(G01).

"🟢" indicates that the timer sterilization function is on, "⚪" indicates that the timer sterilization function is off, "🕒" indicates that the unit does not have the timer sterilization function.

Note: Timing is on for the day of the week, otherwise the timing will not work.

3) Timed Turn-on DHW Water Pump

At the setting interface, press "🕒" in the settings screen, then press "Timed on DHW Water Pump" enter the function.

Operating conditions: Enable this function

parameters(N21 and P08) .

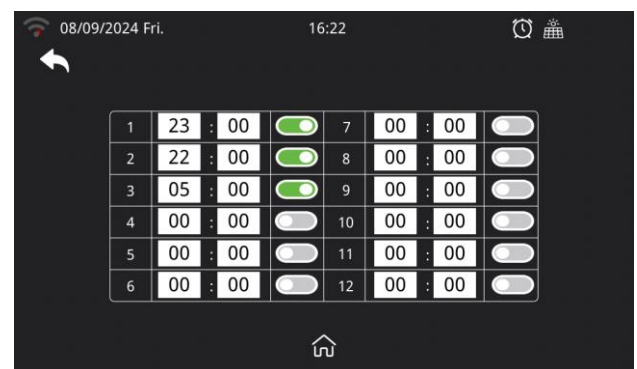
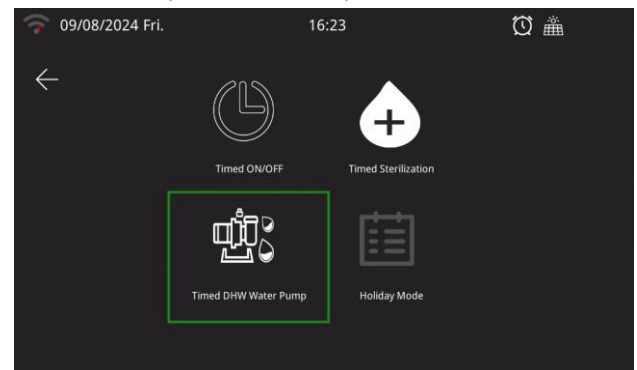

"🕒" indicates that t function is working,

"🕒" indicates that function is stop,

"🕒" indicates that the function disabled.

4) Holiday Mode

At the setting interface, press "🕒" in the settings screen, then press "📅" select holiday mode.

Operating conditions: The heating mode of the unit is enabled, otherwise it cannot enter the holiday mode.

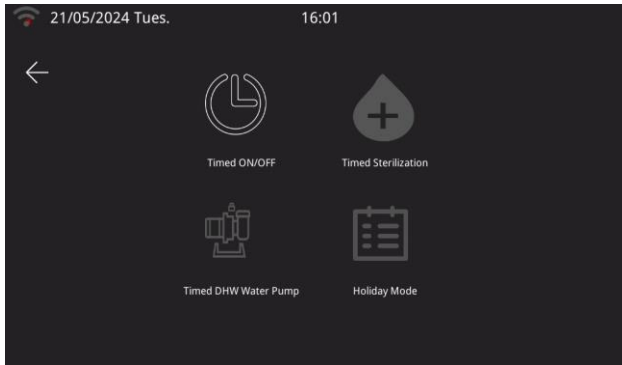

"📅" indicates that the timed holiday function is enabled, "🕒" indicates that the timed holiday function is not enabled, "📅" indicates that the unit does not have the timed holiday function.

Note: When holiday leave home mode and holiday at home mode are turned on at the same time, holiday leave mode is the highest authority. Holiday enter when executing the holiday mode when executing the target temperature, exit holiday mode to execute the normal setting target temperature, enter the holiday mode when not allowed to operate the line controller, operation of the line controller will pop-up window whether to exit the holiday mode.

Use scenarios

a) Holiday at home mode: you can set the indoor temperature and water temperature for each time period (for example: the temperature is colder in the early morning you can set a period of time to set the target

temperature higher, the temperature is more suitable at noon you can set a period of time to set the target temperature lower, the temperature drops in the evening set a period of time to set the target temperature higher).
b) Holiday leave mode: when no one lives at home, you can keep the room a minimum temperature operation.

2.3.18. Heating Function

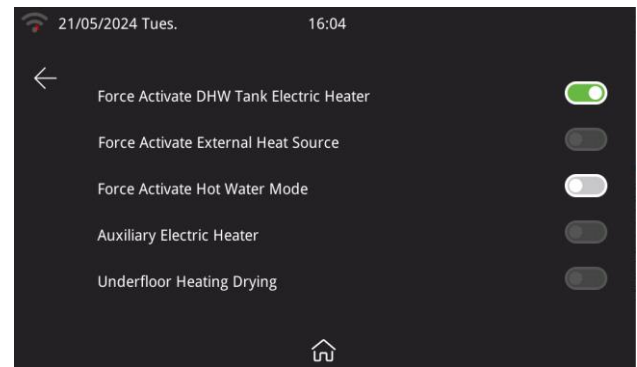

1) Force Start Water Tank Electric Heater

At the setting interface, press "🔌" to enter the electric heater interface. Select ON/OFF.

Operating conditions:

- a) The unit is turned on the hot water function and the current operation contains hot water mode.
- b) If the hot water temperature of the unit > the target temperature of hot water, the hot water temperature of the unit < the target temperature of hot water - the hot water Temp. difference
- c) Unit hot water temperature < hot water target temperature - 1°
- d) The electric tank heating function is enabled.
- e) If one of the conditions a-d is not met, the electric heater cannot be forced on.

2) Force Start Hot Water Mode

At the setting interface, press "🔌" to enter the hot water mode interface. Select ON/OFF.

Operating conditions:

The unit turns on the hot water function, otherwise it cannot be turned on to forced hot

water mode.

3) Force Start External Heat Source

At the setting interface, press “” to enter the external heat source interface. Select ON/OFF.

Operating conditions:

The unit turns on the external heat source (parameter M40 and N37), otherwise it cannot be turned on to forced external heat source mode.

4) Underfloor Heating Drying

At the setting interface, press “” to enter the underfloor heating drying interface. Select ON/OFF.

Operating conditions:

The unit underfloor heating inlet temperature sensor on, otherwise the underfloor heating drying function cannot be switched on.

2.3.19. Preheat Function

- a) When the machine enters the warm-up mode, the main page “” flashes
- b) Quick warm-up

In the main interface, click “” will pop-up window, select "Fast" to enter the fast warm-up function, fast warm-up time is 10min, click the blank position to return to the main interface.

- c) Exit the warm-up function.

In the main interface, click “” will pop-up window, select "Cancel" to directly exit the warm-up function; click on the blank position to return to the main interface.

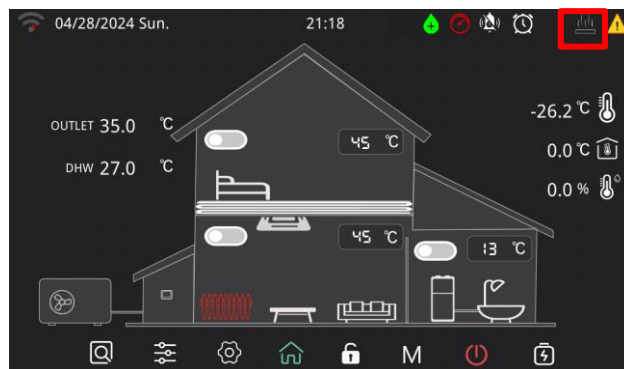

2.3.20. Water Pump Operation Mode

At the system parameter interface, press



and input the password “168” to enter

the customer management interface. Click P01 parameter to modify the pump operation mode. You can choose Always running / intermittent operation / stop temp. Reached.

	Para.M	Para.N	Para.G	Para.P
P01	Water Pump Mode after Target Temp.Reached			0
P02	Inverter Water Pump Setting			0
P03	Inverter Water Pump Target Speed			426 rpm
P04	Inverter Water Pump Code			427
P05	Inverter Water Pump Target Flow Rate			428 L/H
P06	DHW Water Pump Running Time			429 Min
P07	DHW Water Pump Sterilization Setting			Disable

2.3.21. Climate Curve

At the system parameter interface, press “

1. Cooling climate curve

- Users can choose to enable any one curve according to the following table.
- Users can set the curve parameters by themselves, set the parameters as follows: Curve 9 Cooling Ambient Temp.1, Curve 9 Cooling Ambient Temp.2, Curve 9 Cooling Outlet Temp.1, Curve 9 Cooling Outlet Temp.2. (The target temperature value is calculated according to the linear relationship $y=kx+b$.)

Ambient Temp	$-10 \leq TA < 15$	$15 \leq TA < 22$	$22 \leq TA < 30$	$30 \leq TA$
Low Temp.1	16	11	8	5
Low Temp.2	17	12	9	6
Low Temp.3	18	13	10	7
Low Temp.4	19	14	11	8
Low Temp.5	20	15	12	9
Low Temp.6	21	16	13	10
Low Temp.7	22	17	14	11
Low Temp.8	23	18	15	12
High Temp.1	20	18	17	16
High Temp.2	21	19	18	17
High Temp.3	22	20	19	17
High Temp.4	23	21	19	18
High Temp.5	24	21	20	18
High Temp.6	24	22	20	19
High Temp.7	25	22	21	19
High Temp.8	25	23	21	20

2. Heating climate curve

a) Users can choose to enable any one curve according to the following table.

b) Users can set the curve parameters by themselves, set the parameters as follows: Curve 9

Heating Ambient Temp.1, Curve 9 Heating Ambient Temp.2, Curve 9 Heating Outlet

Temp.1, Curve 9 Heating Outlet Temp.2. (The target temperature value is calculated according to the linear relationship $y=kx+b$.)

Ambient Temp.	≤ -20	-19	-18	-17	-16	-15	-14	-13	-12	-11	-10	-9	-8	-7	-6	-5	-4
Low Temp.1	38	38	38	38	38	37	37	37	37	37	37	36	36	36	36	36	36
Low Temp.2	37	37	37	37	37	36	36	36	36	36	36	35	35	35	35	35	35
Low Temp.3	36	36	36	35	35	35	35	35	35	34	34	34	34	34	34	33	33
Low Temp.4	35	35	35	34	34	34	34	34	34	33	33	33	33	33	33	32	32
Low Temp.5	34	34	34	33	33	33	33	33	33	32	32	32	32	32	32	31	31
Low Temp.6	32	32	32	32	31	31	31	31	31	31	31	31	30	30	30	30	30
Low Temp.7	31	31	31	31	30	30	30	30	30	30	30	30	29	29	29	29	29
Low Temp.8	29	29	29	29	28	28	28	28	28	28	28	28	27	27	27	27	27
High Temp.1	55	55	55	55	54	54	54	54	54	54	54	54	53	53	53	53	53
High Temp.2	53	53	53	53	52	52	52	52	52	52	52	52	51	51	51	51	51
High Temp.3	52	52	52	52	51	51	51	51	51	51	51	51	50	50	50	50	50
High Temp.4	50	50	50	50	49	49	49	49	49	49	49	49	48	48	48	48	48
High Temp.5	48	48	48	48	47	47	47	47	47	47	47	47	46	46	46	46	46
High Temp.6	45	45	45	45	44	44	44	44	44	44	44	44	43	43	43	43	43
High Temp.7	43	43	43	43	42	42	42	42	42	42	42	42	41	41	41	41	41
High Temp.8	40	40	40	40	39	39	39	39	39	39	39	39	38	38	38	38	38
Ambient Temp.	-3	-2	-1	0	1	2	3	4	5	6	7	8	9	10	11	12	13
Low Temp.1	35	35	35	35	35	35	34	34	34	34	34	34	34	33	33	33	33
Low Temp.2	34	34	34	34	34	34	33	33	33	33	33	33	32	32	32	32	32
Low Temp.3	33	33	33	33	32	32	32	32	32	32	31	31	31	31	31	31	30
Low Temp.4	32	32	32	32	31	31	31	31	31	31	30	30	30	30	30	30	29
Low Temp.5	31	31	31	31	30	30	30	30	30	30	29	29	29	29	29	29	28
Low Temp.6	30	30	30	29	29	29	29	29	29	29	28	28	28	28	28	28	27
Low Temp.7	29	29	29	28	28	28	28	28	28	28	27	27	27	27	27	27	26
Low Temp.8	27	27	27	26	26	26	26	26	26	26	26	25	25	25	25	25	25
High Temp.1	53	53	53	53	53	52	52	52	52	52	52	52	52	51	51	51	51
High Temp.2	51	51	51	51	51	50	50	50	50	50	50	50	50	49	49	49	49
High Temp.3	50	50	50	50	50	49	49	49	49	49	49	49	49	48	48	48	48
High Temp.4	48	48	48	48	48	47	47	47	47	47	47	47	47	46	46	46	46
High Temp.5	46	46	46	46	46	45	45	45	45	45	45	45	45	44	44	44	44
High Temp.6	43	43	43	43	43	42	42	42	42	42	42	42	42	41	41	41	41
High Temp.7	41	41	41	41	41	40	40	40	40	40	40	40	40	39	39	39	39
High Temp.8	38	38	38	38	38	37	37	37	37	37	37	37	37	36	36	36	36
Ambient Temp.	14	15	16	17	18	19	≥										

							20											
Low Temp.1	33	32	32	32	32	32	32											
Low Temp.2	32	31	31	31	31	31	31											
Low Temp.3	30	30	30	30	30	29	29											
Low Temp.4	29	29	29	29	29	28	28											
Low Temp.5	28	28	28	28	28	27	27											
Low Temp.6	27	27	27	27	27	26	26											
Low Temp.7	26	26	26	26	26	25	25											
Low Temp.8	25	25	24	24	24	24	24											
High Temp.1	51	51	50	50	50	50	50											
High Temp.2	49	49	48	48	48	48	48											
High Temp.3	48	48	47	47	47	47	47											
High Temp.4	46	46	45	45	45	45	45											
High Temp.5	44	44	43	43	43	43	43											
High Temp.6	41	41	40	40	40	40	40											
High Temp.7	39	39	38	38	38	38	38											
High Temp.8	36	36	35	35	35	35	35											

Custom Curve—Cooling

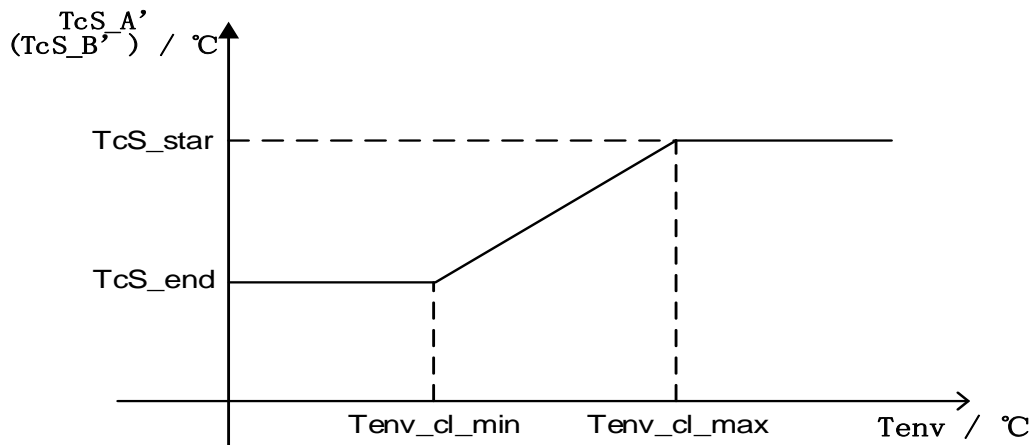

$T_{env_cl_max}$: MAX(【Custom Curve of Cooling Ambient Temp.1】, 【Custom Curve of Cooling Ambient Temp.2】)

$T_{env_cl_min}$: MIN(【Custom Curve of Cooling Ambient Temp.1】, 【Custom Curve of Cooling Ambient Temp.2】)

T_{cS_end} : MIN(【Custom Curve of Cooling Outlet Temp. 1】, 【Custom Curve of Cooling Outlet Temp. 2】)

T_{cS_star} : MAX(【Custom Curve of Cooling Outlet Temp. 1】, 【Custom Curve of Cooling Outlet Temp. 2】)

Custom Curve—Heating

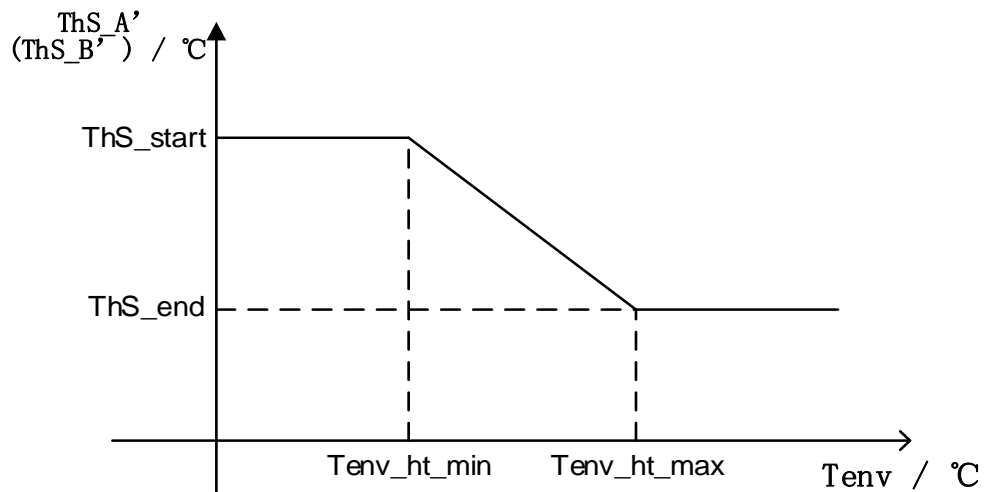

Tenv_ht_max: MAX(【Custom Curve of Heating Ambient Temp. 1】 , 【Custom Curve of Heating Ambient Temp. 2】)

Tenv_ht_min: MIN(【Custom Curve of Heating Ambient Temp. 1】 , 【Custom Curve of Heating Ambient Temp. 2】)

ThS_end: MIN(【Custom Curve of Heating Outlet Temp.1】 , 【Custom Curve of Heating Outlet Temp.2】)

ThS_start: MAX(【Custom Curve of Heating Outlet Temp.1】 , 【Custom Curve of Heating Outlet Temp.2】)

2.4.APPENDIX

2.4.1. Parameters

Note: Parameters can only be modified when the unit is powered off, otherwise the parameters cannot be modified successfully.

Code	Parameter	Unit	Range
N01	Power Mode	/	0 Standard/1 Powerful/2 Eco/3 Auto
N02	Heating & Cooling Type	/	0 Heating only/1 Heating & Cooling / 2 Cooling only
N04	Four-Way Valve Setting	/	0 Heating open valve/1 Cooling open valve
N05	Wire control switch type	/	0 Toggle switch/1 Pulse switch
N06	Unit Start/Stop Control	/	0 Union/1 Remote/2 Local/3 Wire Control/4 Net control
N07	Power Down Memory	/	0 Disable/1 Enable
N08	Incoming Power Self-Start	/	0 Disable/1 Enable
N11	Hot Water Function	/	0 Disable/1 Enable
N20	Tank Electric Heating	/	0 Disable/1 Enable
N21	Lower Return Pump	/	0 Disable/1 Enable
N22	Solar	/	0 Disable/1 Enable
N23	Linkage Switch Setting	/	0 Disable/1 Linkage Action is Valid/2 Linkage Closure is Valid/3 Power ON/OFF via Wire Controller /4 Control DHW Electric Heater via Wire Controller/5 Control External Heat Source via Wire Controller
N26	Wire Controller Control Type	/	0 Single Zone/ 2 Double Zone
N32	Smart Grid	/	0 Disable/1 Enable
N36	Underfloor Heating Inlet Temp. Sensor	/	0 Disable/1 Enable
N37	System Total Outlet Water Temp. Sensor	/	0 Disable/1 Enable
N38	EVU PV Signal	/	0 Normally open/1 Normally closed
N39	SG Grid Signal	/	0 Normally open/1 Normally closed
N41	Solar Temp. Sensor	/	0 Disable/1 Enable
N48	Zone A cooling end	/	0 Radiator/ 1 Fan Coil/ 2 Underfloor Heating
N49	Zone A heating end	/	0 Radiator/ 1 Fan Coil/ 2 Underfloor Heating
M01	Cooling Setting	°C	15~35

	Temp.		
M02	Heating Setting Temp.	°C	0~85
M03	Hot Water Setting Temp.	°C	0~80
M08	Heating Setting Temp.(B)	°C	40~60
M10	A Zone Cooling Curve	/	0 Disable/ 1 Low Temp. Curve 1/ 2 Low Temp. Curve 2/ 3 Low Temp. Curve 3/4 Low Temp. Curve 4/ 5 Low Temp. Curve 5/ 6 Low Temp. Curve 6/ 7 Low Temp. Curve 7/ 8 Low Temp. Curve 8/ 9 High Temp. Curve 1/ 10 High Temp. Curve 2/ 11 High Temp. Curve 3/ 12 High Temp. Curve 4/ 13 High Temp. Curve 5/ 14 High Temp. Curve 6/ 15 High Temp. Curve 7/ 16 High Temp. Curve 8/ Custom Curve
M11	A Zone Heating Curve	/	0 Disable/ 1 Low Temp. Curve 1/ 2 Low Temp. Curve 2/ 3 Low Temp. Curve 3/4 Low Temp. Curve 4/ 5 Low Temp. Curve 5/ 6 Low Temp. Curve 6/ 7 Low Temp. Curve 7/ 8 Low Temp. Curve 8/ 9 High Temp. Curve 1/ 10 High Temp. Curve 2/ 11 High Temp. Curve 3/ 12 High Temp. Curve 4/ 13 High Temp. Curve 5/ 14 High Temp. Curve 6/ 15 High Temp. Curve 7/ 16 High Temp. Curve 8/ Custom Curve
M12	B Zone Cooling Curve	/	0 Disable/ 1 Low Temp. Curve 1/ 2 Low Temp. Curve 2/ 3 Low Temp. Curve 3/4 Low Temp. Curve 4/ 5 Low Temp. Curve 5/ 6 Low Temp. Curve 6/ 7 Low Temp. Curve 7/ 8 Low Temp. Curve 8/ 9 High Temp. Curve 1/ 10 High Temp. Curve 2/ 11 High Temp. Curve 3/ 12 High Temp. Curve 4/ 13 High Temp. Curve 5/ 14 High Temp. Curve 6/ 15 High Temp. Curve 7/ 16 High Temp. Curve 8/ Custom Curve
M13	B Zone Heating Curve	/	0 Disable/ 1 Low Temp. Curve 1/ 2 Low Temp. Curve 2/ 3 Low Temp. Curve 3/4 Low Temp. Curve 4/ 5 Low Temp. Curve 5/ 6 Low Temp. Curve 6/ 7 Low Temp. Curve 7/ 8 Low Temp. Curve 8/ 9 High Temp. Curve 1/ 10 High Temp. Curve 2/ 11 High Temp. Curve 3/ 12 High Temp. Curve 4/ 13 High Temp. Curve 5/ 14 High Temp. Curve 6/ 15 High Temp. Curve 7/ 16 High Temp. Curve 8/ Custom Curve

M14	Custom Curve of Cooling Ambient Temp.1	°C	-5~46
M15	Custom Curve of Cooling Ambient Temp. 2	°C	-5~46
M16	Custom Curve of Cooling Outlet Temp. 1	°C	5~25
M17	Custom Curve of Cooling Outlet Temp. 2	°C	5~25
M18	Custom Curve of Heating Ambient Temp. 1	°C	-25~35
M19	Custom Curve of Heating Ambient Temp.2	°C	-25~35
M20	Custom Curve of Heating Outlet Temp.1	°C	25~65
M21	Custom Curve of Heating Outlet Temp.2	°C	25~65
M35	Min. Ambient Temp.of Automatic Cooling	°C	20~29
M36	Max. Ambient Temp.of Automatic Cooling	°C	10~17
M37	Holiday away Home Heating	°C	20~25
M38	Holiday away Home Hot Water	°C	20~25
M40	External Heat Source	/	0 Disable/1 Heating only/2 Hot water only/3 Heating & Hot water
M55	Underfloor Heating Preheating Temp.	°C	25~35
M56	Underfloor Heating Preheating Interval	Min	10~40
M57	Underfloor Heating Preheating Time	H	48~96
M58	Underfloor Heating Water Temp. Return	°C	0~10

M59	Underfloor Heating Room Temp. Return Difference	°C	0~10
M60	Underfloor Heating Before Drying	DAY	4~15
M61	Underfloor Heating During Drying	DAY	3~7
M62	Underfloor Heating After Drying	DAY	4~15
M63	Underfloor Heating Drying Temp.	°C	30~55
F06	Variable Frequency Fan Speed Adjustment	/	0 Manual/1 Ambient Temp. Linear/2 Fin Temp. Linear
F07	Fan Manual Operation	rps	0~2000
P01	Water Pump Operation Mode	/	0 Keep Running /1 Intermittent Operation /2Stop When Temp. Reached
P02	Water Pump Control Type	/	1 Control Speed/2 Control Flow Rate/3 ON/OFF/4 Control Power
P03	Water Pump Target Speed	rpm	1000~4500
P04	Water Pump Manufacturers	/	0~4
P05	Water Pump Target Flow Rate	undefined	0~4500
P06	Lower Return Water Pump Operation	Min	5~120
P07	Lower Return Water Pump Sterilization	/	0 Disable/1 Enable
P08	Lower Return Water Pump Timed	/	0 Disable/1 Enable
G01	Timed Sterilization Function	/	0~1 0 Disable/1 Enable
G02	Sterilization Temp.	°C	60~70
G03	Sterilization Max. cycle	Min	90~300
G04	Sterilization high Temp. time	Min	5~60

2.4.2. Error code

Code	Description	Causes	Solutions
E01	Wire controller communication fault	<ol style="list-style-type: none"> 1.The connection between wire controller and main board is poor. 2. Wire controller fault. 3. Main board fault. 4. Communication wire and strong electricity wire put together, resulting in power interference communication 	<ol style="list-style-type: none"> 1. Reconnect the wire controller cable. 2. Replace the wire controller. 3. Replace the main board. 4. Communication wire is placed separately from the strong electricity wire.
E03	0#Compressor high pressure	<ol style="list-style-type: none"> 1. Check for refrigerant leaks 2. The throttle device is dirty and blocked, damaged 3. Compressor bearing damage, causing mechanical part friction, exhaust temperature rise 4. High pressure switch fault 5. Main board fault 6. Compressor fault 	<ol style="list-style-type: none"> 1.Refill refrigerant 2.Clean/replace throttle device 3.Replace compressor 4.Replace the high pressure switch 5.Replace the main board 6.Replace the compressor
E04	0#Compressor low pressure	<ol style="list-style-type: none"> 1.Insufficient water flow 2.Low chilled water inlet water temperature 3.Refrigerant leakage or insufficient refrigerant charge 4.Scale in evaporator 	<ol style="list-style-type: none"> 1.Check the temperature difference between the inlet and outlet water and adjust the water flow 2.Check the installation 3.Leak detection or filling with sufficient refrigerant 4.Remove water scale
E06	0#Inverter communication fault	<ol style="list-style-type: none"> 1. Power supply voltage fault 2. Inverter board fault 3. Main board fault 	<ol style="list-style-type: none"> 1. Replace the power cord 2. Replace the inverter board 3.Replace the main board
E06	0#Communication fault	<ol style="list-style-type: none"> 1. Communication lines and strong wires placed together, resulting in communication power interference 2. Poor connection between the module machine and the main board. 3. Main board fault 	<ol style="list-style-type: none"> 1.Communication wire is placed separately from the strong electricity wire. 2.Reconnect the wires 3.Replace the main board.

Code	Description	Causes	Solutions
E10	Floor heating water inlet temperature fault	1.Whether the wiring is loose/damaged 2.Temperature sensor fault 3.Main board fault	1.Rewiring/replacement of wires 2. Replace the temperature sensor 3. Replace the main board
E11	Total outlet water temperature fault	1.Whether the wiring is loose/damaged 2.Temperature sensor fault 3.Main board fault	1.Rewiring/replacement of wires 2. Replace the temperature sensor 3. Replace the main board
E11	System total outlet water temperature fault	1.Whether the wiring is loose/damaged 2.Temperature sensor fault 3.Main board fault	1.Rewiring/replacement of wires 2. Replace the temperature sensor 3. Replace the main board
E11	0#Plate exchanger outlet water Temp. fault	1.Whether the wiring is loose/damaged 2.Temperature sensor fault 3.Main board fault	1.Rewiring/replacement of wires 2. Replace the temperature sensor 3. Replace the main board
E11	0# Total water outlet Temp. fault	1.Whether the wiring is loose/damaged 2.Temperature sensor fault 3.Main board fault	1.Rewiring/replacement of wires 2. Replace the temperature sensor 3. Replace the main board
E12	Hot water tank temperature fault	1.Whether the wiring is loose/damaged 2.Temperature sensor fault 3.Main board fault	1.Rewiring/replacement of wires 2. Replace the temperature sensor 3. Replace the main board
E12	Buffer tank upper temperature fault	1.Whether the wiring is loose/damaged 2.Temperature sensor fault 3.Main board fault	1.Rewiring/replacement of wires 2. Replace the temperature sensor 3. Replace the main board
E12	Buffer tank lower temperature fault	1.Whether the wiring is loose/damaged 2.Temperature sensor fault 3.Main board fault	1.Rewiring/replacement of wires 2. Replace the temperature sensor 3. Replace the main board

Code	Description	Causes	Solutions
E13	Indoor temperature fault	1.Whether the wiring is loose/damaged 2.Temperature sensor fault 3.Main board fault	1.Rewiring/replacement of wires 2. Replace the temperature sensor 3. Replace the main board
E14	0# Ambient Temp. fault	1.Whether the wiring is loose/damaged 2.Temperature sensor fault 3.Main board fault	1.Rewiring/replacement of wires 2. Replace the temperature sensor 3. Replace the main board
E16	0#Exhaust temperature fault	1.Whether the wiring is loose/damaged 2.Temperature sensor fault 3.Main board fault	1.Rewiring/replacement of wires 2. Replace the temperature sensor 3. Replace the main board
E21	EEPROM data error	Data reading error	Shutdown and restart
E21	0#EEPROM data error		
E24	0#High plate return water temperature	1.Whether the wiring is loose/damaged 2.Heat exchanger is blocked 3.Temperature sensor fault 4.Main board fault	1.Rewiring/replacement of wires 2.Cleaning of heat exchangers 3.Replace the temperature sensor 4.Replace the main board
E24	0#Plate Inlet Water Temp. too High	1. Low water flow 2. Clogged water pipes 3. Water pipe damage 4. Sensor fault	1. Clear the blockage 2. Check whether the water flow of the pump meets the requirements 3. Replace the water pipe 4. Replace the sensor
E25	0#Cooling Evaporation is Too Low		
E25	0#Plate Exchanger Outlet Water Temp. Too Low		
E25	0#Plate Inlet Water Temp. too Low		
E26	0#Outlet and Inlet Water Temp. Difference Abnormal		
E26	0#Outlet and Inlet Water Temp. Difference is Too Large		

Code	Description	Causes	Solutions
E27	0#Exhaust temperature too high		
E31	0#J5 pressure sensor fault	1.Whether the wiring is loose/damaged 2.Temperature sensor fault 3.Main board fault	1.Rewiring/replacement of wires 2. Replace the temperature sensor 3. Replace the main board
E32	0#J6 pressure sensor fault	1.Whether the wiring is loose/damaged 2.Temperature sensor fault 3.Main board fault	1.Rewiring/replacement of wires 2. Replace the temperature sensor 3. Replace the main board
E44	0#Plate Exchanger Inlet Water Temp. Fault	1.Whether the wiring is loose/damaged 2.Temperature sensor fault 3.Main board fault	1.Rewiring/replacement of wires 2. Replace the temperature sensor 3. Replace the main board
E55	0#Suction temperature fault	1.Whether the wiring is loose/damaged 2.Temperature sensor fault 3.Main board fault	1.Rewiring/replacement of wires 2. Replace the temperature sensor 3. Replace the main board
E56	Solar Temp. sensor fault	1.Whether the wiring is loose/damaged 2.Temperature sensor fault 3.Main board fault	1.Rewiring/replacement of wires 2. Replace the temperature sensor 3. Replace the main board
E58	0#Coil Temp. Fault	1.Whether the wiring is loose/damaged 2.Temperature sensor fault 3.Main board fault	1.Rewiring/replacement of wires 2. Replace the temperature sensor 3. Replace the main board
E59	0#Suction temperature too low	1. Too much/too little refrigerant 2.Temperature sensor fault 3. Main board fault	1.Refill the refrigerant according to the nameplate 2.Replace the temperature sensor 3.Replace the main board
E60	0#Frequent emergency defrost	1. Ambient temperature sensor is damaged 2.Dirty and blocked heat exchanger 3. Lack of refrigerant	1.Replace the ambient temperature sensor 2.Clean the heat exchanger 3.Refill the refrigerant according to the nameplate

Code	Description	Causes	Solutions
E61	0#Abnormal Temp. difference between suction and exhaust	<ol style="list-style-type: none"> 1. Inlet and outlet water temp. sensor fault. 2. The valve in water system is not open. 3. Waterway blockage, may appear in the heat exchanger or valve part. 4. Improper water pump selection 5. The water pump is broken . 6. Pipe size is too small. 7. Heat exchanger is fouling. 	<ol style="list-style-type: none"> 1. Need to replace the temp. sensor. 2. Clean or replace the blocked part. 3. Change the pump according to the water flow and water head. 4. Need to change the water pipe. 5. Reset the water flow switch manually. 6. Choose the suitable pipe size. 7. Clean the dirt of the heat exchanger surface.
E62	Fan coil communication fault 1-32	<ol style="list-style-type: none"> 1. Connection cable fault 2. Power input fault 3. Main board fault 	<ol style="list-style-type: none"> 1. Check wiring and rewire 2. Replace the power cord 3. Replace the main board
E63	0#Communication abnormal	<ol style="list-style-type: none"> 1. Communication lines and strong wires placed together, resulting in communication power interference 2. Poor connection between the module machine and the main board. 3. Main board fault 	<ol style="list-style-type: none"> 1. Communication wire is placed separately from the strong electricity wire. 2. Reconnect the wires 3. Replace the main board.
E63	0#Internal and external machine communication fault		
E64	0#Protocol version too low	Program error	Update procedure
E65	0#Abnormal model setting	<ol style="list-style-type: none"> 1. Main board code error 2. The program did not restore the factory settings 	<ol style="list-style-type: none"> 1. Resetting the main board code 2. Re-download the program
E66	System maintenance data error	System maintenance data error	Recovery parameters in parameter setting

Code	Description	Causes	Solutions
E67	Water Tank Electric Heater Overload	1.Voltage input error 2.Water tank damage	1.Check power supply wiring/reconnect power supply voltage 2.Repair of water tank
E68	0# Insufficient water flow	1.The water system is blocked 2.Water pump is not suitable 3. Water pipe is small 4.The water flow switch is stuck and cannot be reset.	1.Check if the pump is running properly/Clean or replace the blocked part 2.Change the pump according to the water flow and water head 3.Need to change the water pipe 4.Reset the water flow switch manually.
E69	0# Refrigerant gas side Temp. fault	1.Whether the wiring is loose/damaged 2.Temperature sensor fault 3.Main board fault	1.Rewiring/replacement of wires 2. Replace the temperature sensor 3. Replace the main board
E70	0#Refrigerant liquid side Temp. fault	1.Whether the wiring is loose/damaged 2.Temperature sensor fault 3.Main board fault	1.Rewiring/replacement of wires 2. Replace the temperature sensor 3. Replace the main board
F16	0#Compressor low pressure too low	1.Insufficient water flow 2.Low chilled water inlet water temperature 3.Refrigerant leakage or insufficient refrigerant charge 4.Scale in evaporator	1.Check the temperature difference between the inlet and outlet water and adjust the water flow 2.Check the installation 3.Leak detection or filling with sufficient refrigerant 4.Remove water scale

Code	Description	Causes	Solutions
F17	0#Compressor high pressure too high	<ol style="list-style-type: none"> 1. Less refrigerant 2.The throttle device is dirty and blocked, damaged 3. Compressor bearing damage, causing mechanical part friction, exhaust temperature rise 4.High pressure switch fault 5.Main board fault 6.Compressor fault 	<ol style="list-style-type: none"> 1.Refill refrigerant 2.Clean/replace throttle device 3.Replace compressor 4.Replace the high pressure switch 5.Replace the main board 6.Replace the main board compressor
F61	0#Abnormal speed of fan 1	<ol style="list-style-type: none"> 1.Loose connection cable 2.Unstable voltage 	<ol style="list-style-type: none"> 1.Reconnect the motherboard and fan wiring 2. Replace the stable voltage
F61	0#Abnormal speed of fan 2	<ol style="list-style-type: none"> 3. Main board fault 4. Fan fault 	<ol style="list-style-type: none"> 3. Replace the Main board 4. Replace the fan
F62	Fault of fan coil 01-32	<ol style="list-style-type: none"> 1. Power input is not normal 2. Whether the fan coil is rotating 3. Whether the fan coil is blocked 4. The fan coil is damaged 	<ol style="list-style-type: none"> 1. Reconnect the power supply 2. Check whether the motor is stuck 3. Clean the fan coil 4. Replace the fan coil
F63	0#Ambient Temp. Restricts compressor Opening	<ol style="list-style-type: none"> 1.Whether the wiring is loose/damaged 2.Temperature sensor fault 3.Main board fault 	<ol style="list-style-type: none"> 1.Rewiring/replacement of wires 2. Replace the temperature sensor 3. Replace the main board
F64	0#Inverter Fault	<ol style="list-style-type: none"> 1.Loose connection cable 2.Unstable voltage 3. Main board fault 4. Driver board fault 	<ol style="list-style-type: none"> 1.Reconnect the wires 2. Replace the stable voltage 3. Replace the Main board 4. Replace the driver board fault

Code	Description	Causes	Solutions
F65	0#Inverter Model Setting in Progress	<ol style="list-style-type: none"> 1. Loose connection cable 2. Pump fault 3. Inverter fault 4. Main board fault 	<ol style="list-style-type: none"> 1. Reconnect the wires 2. Replace the pump 3. Replace the inverter 4. Replace the main board
F66	0#Inverter pump fault	1.The water system is blocked.	1. Clean or replace the blocked part
F66	Inverter water pump fault	<ol style="list-style-type: none"> 2. Loose connection cable 3. Pump fault 4. Inverter fault 5. Main board fault 	<ol style="list-style-type: none"> 2. Reconnect the wires 3. Replace the pump 4. Replace the inverter 5. Replace the main board
F66	0#Inverter pump warning [80%]	1.Whether the wiring is loose/damaged	1.Rewiring/replacement of wires
E75	R290 Sensor Fault	<ol style="list-style-type: none"> 2.R290 sensor broken 3.Main board broken 	<ol style="list-style-type: none"> 2. Replace the R290 sensor 3. Replace the main board
E76	R290 Leakage Alarm	<ol style="list-style-type: none"> 1. gas leakage 2. External gas interference 3. Sensor failure 	<ol style="list-style-type: none"> 1. Find out the leakage area and repaired 2. Clear away distractions 3. Replace the sensor
E77	Water Flow Sensor Fault	<ol style="list-style-type: none"> 1.Whether the wiring is loose/damaged 2.Flow sensor broken 3.Main board broken 	<ol style="list-style-type: none"> 1.Rewiring/replacement of wires 2. Replace the flow sensor 3. Replace the main board

2.5. Wi-Fi FUNCTION

2.5.1. Software Installation

Download Eco-Home from Google Store or Apple Store.



2.5.2. Login / Registration

- (1) Existing accounts can be logged in directly, in the following steps:
- (2) If you forget your password you can choose to login in with your verification code and select "Forget Password": Enter your phone number and get the verification code.
- (3) Users who don't have an account can click "Sign Up Now!" to create an account.
- (4) Set the password.
- (5) Enter your Email, then you will get a verification code.

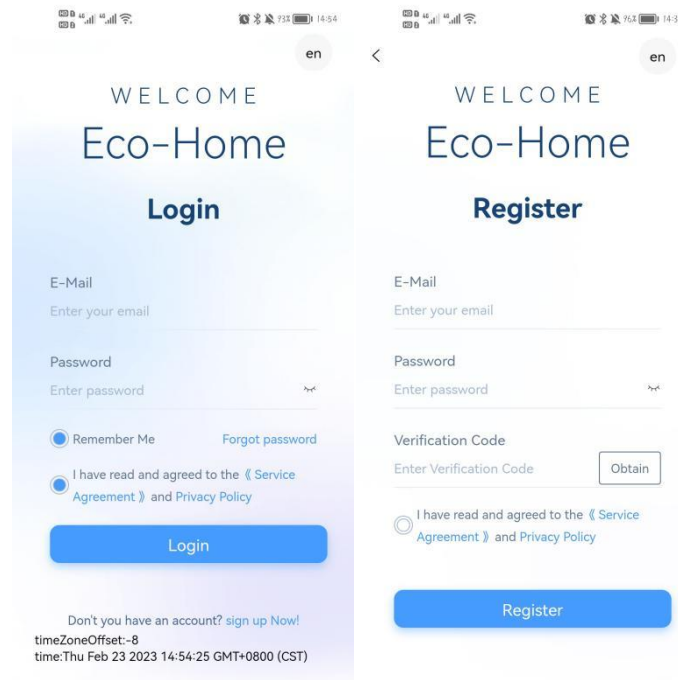

2.5.3. Add Device

Step 1:

Turn on the phone's Bluetooth and Wi-Fi function, then connect to the Wi-Fi . The Wi-Fi must be able to connect to the Internet normally.

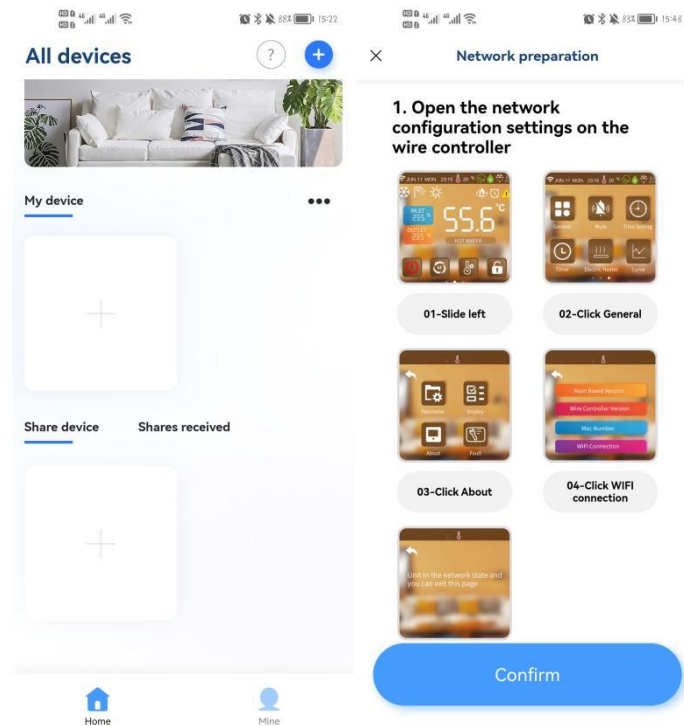

Step 2:

Choose Wi-Fi and enter the password.

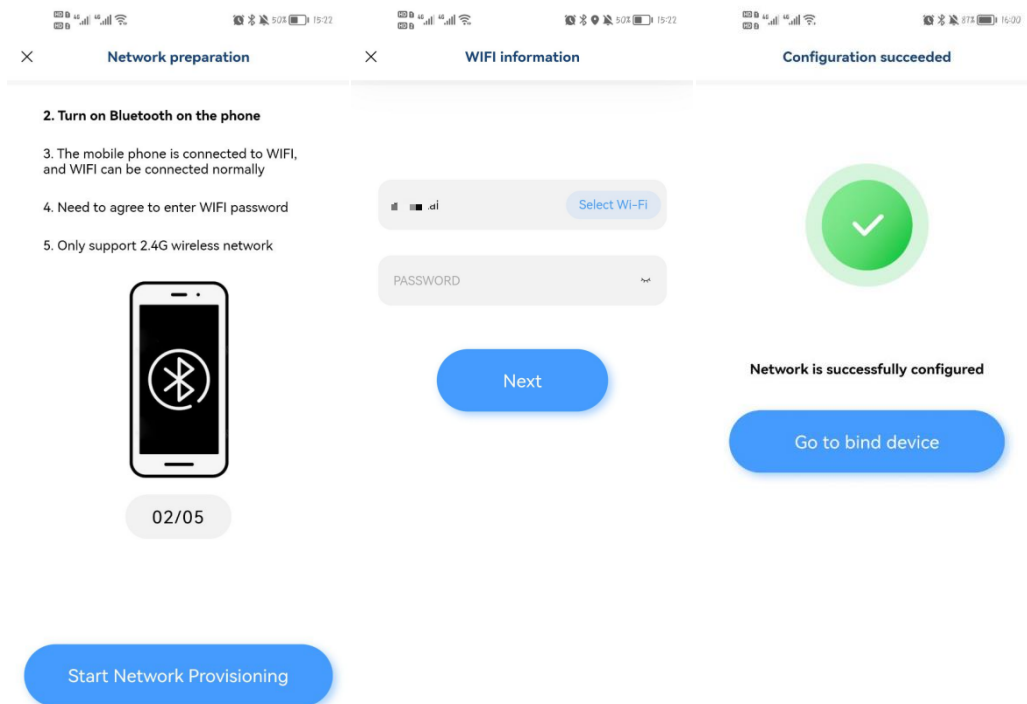

Step 3:

After successful networking, scan the wire controller QR code or enter the serial number to bind the unit. Return to the main page after successful binding.

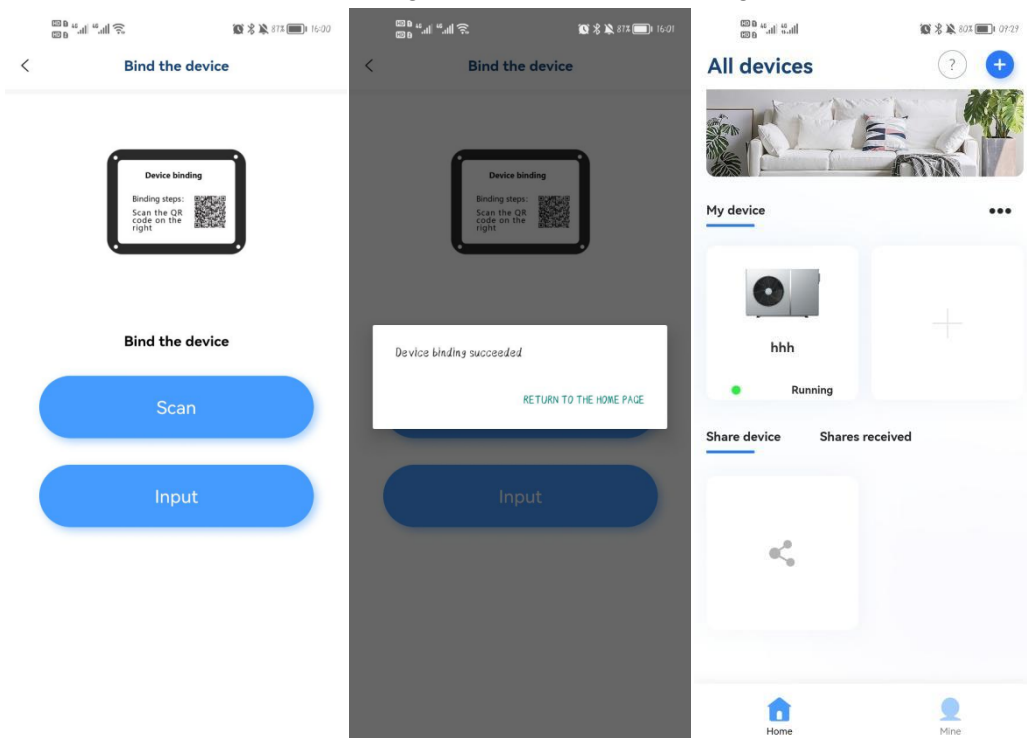

- **Device sharing**

Click "share device", click the unit you want to share, click "Add a share", enter the shared account information, and confirm the share.

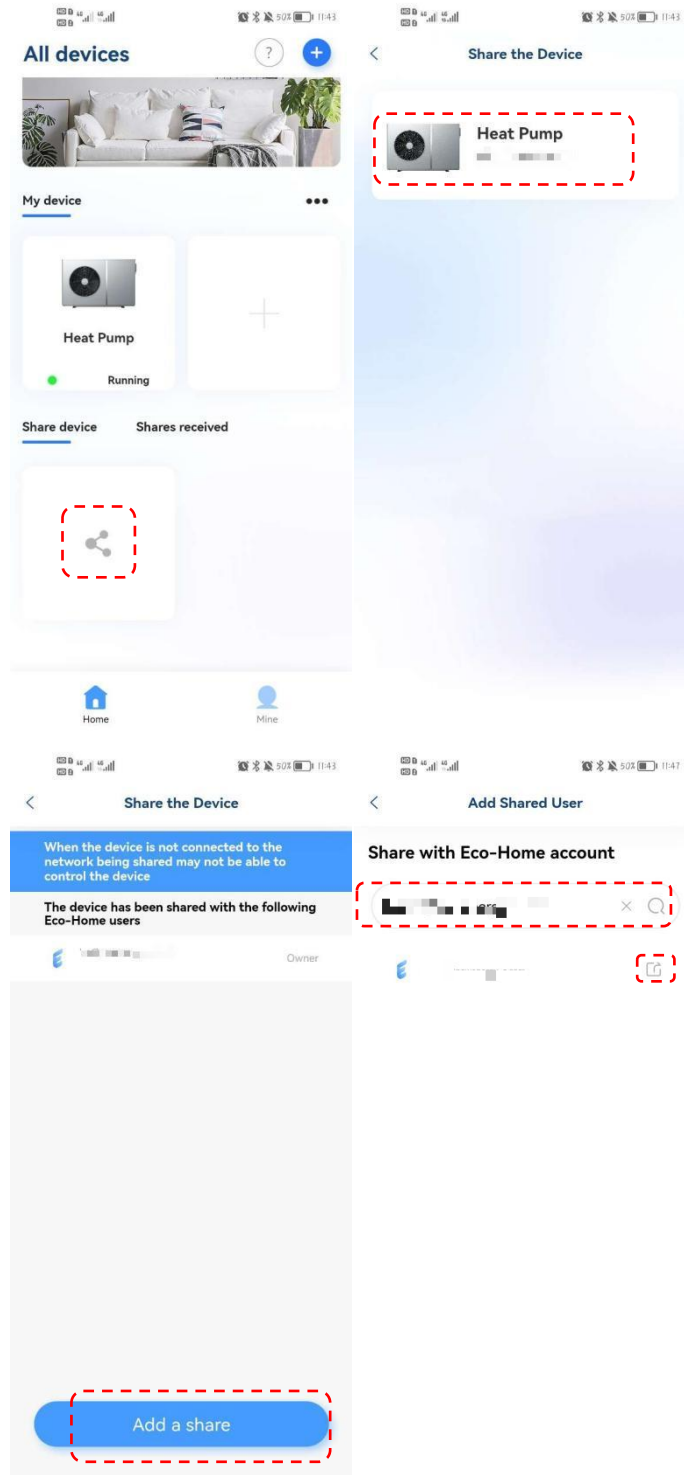

2.5.4. Software Function Operation

- After the device is bound successfully, enter the operation interface of “Eco-Home” (Device name, modifiable)
- In the main interface, click the unit to enter the operation interface.

(1) Heating & Cooling

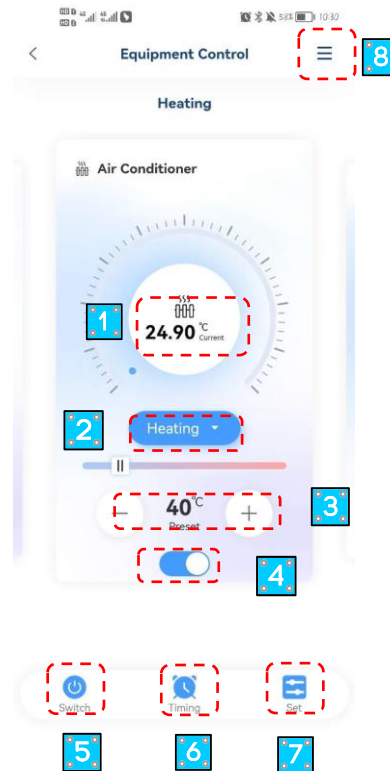

- ① Current Temperature
- ② Mode Settings
- ③ Target Temperature Setting
- ④ ON/OFF
- ⑤ Total ON/OFF
- ⑥ Timer ON/OFF
- ⑦ Set
- ⑧ More Settings

(2) Hot Water



- ① Current Temperature
- ② Target Temperature Setting
- ③ ON/OFF

(3) Floor Heating

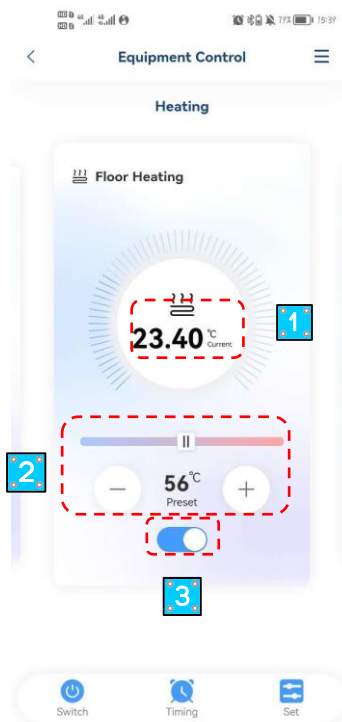

- ① Current Temperature
- ② Target Temperature Setting
- ③ ON/OFF

2.5.5. Modify Device Name / Delete Device

Click in the following order to enter device details, and click "Device Name" to rename the device. Click "Delete the Device" to remove the device.

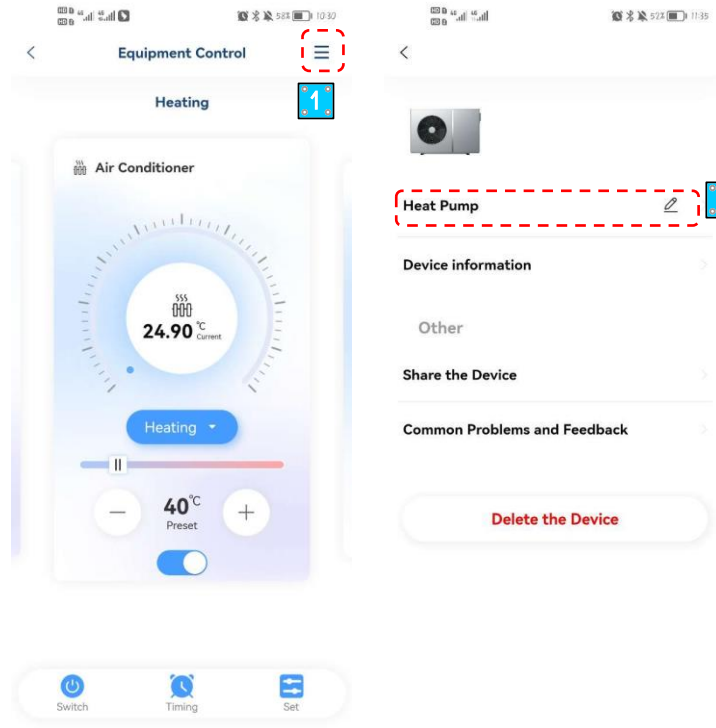

2.5.6. Mode settings

Click to select the mode you need to set.

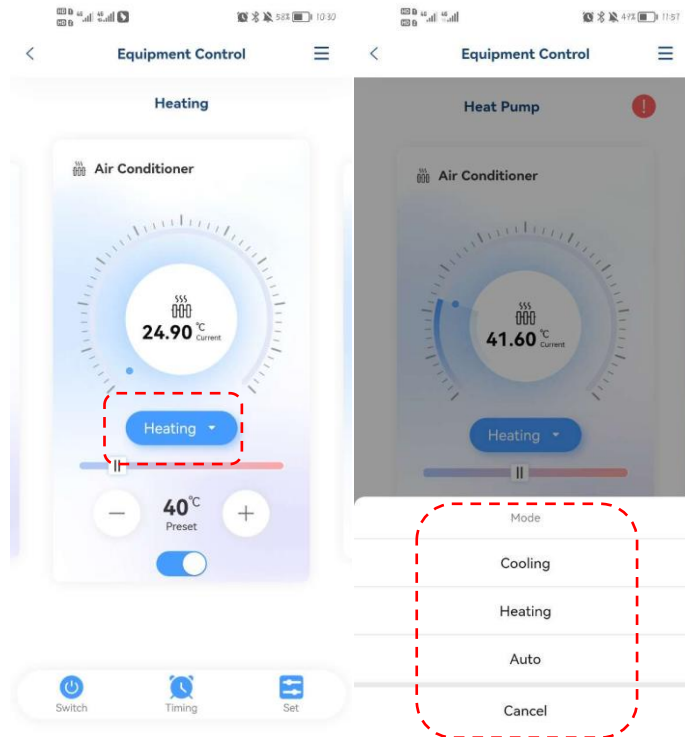

2.5.7. Timing

Click "Timing", then click "+", set the timer and save it.

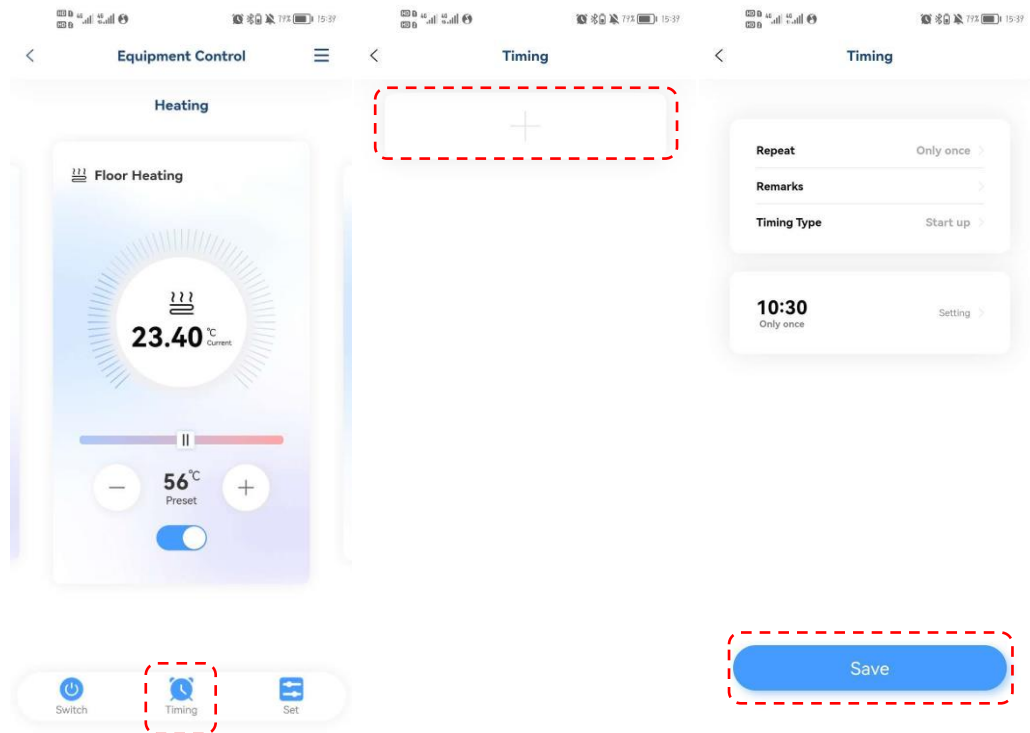

2.5.8. Set Parameters

(1) Set Target Temp.

Support to modify the content of the parameters is: Hot water target temperature, Cooling target temperature, Heating target temperature, Floor heating target temperature, and temperature units (in the modification of temperature units, the controller will re-read the main board and upload it to the APP one by one).



(2) Status Query

You can query the system status and module status.

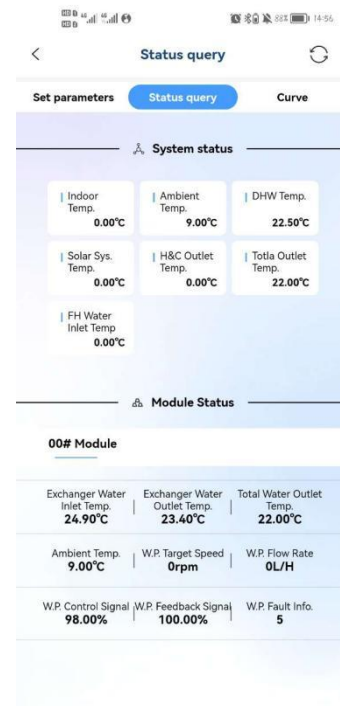

(3) Temperature curve.

The current curve shows the temperature respectively: Exchanger water outlet Temperature, Exchanger water inlet Temperature, Ambient Temperature, DHW Temperature. Real-time curve updates.

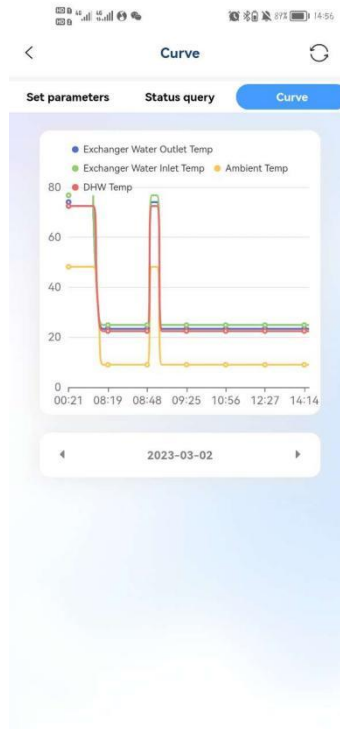

2.5.9. Mine

Click "Mine" for user information, common problems, about, and logout.

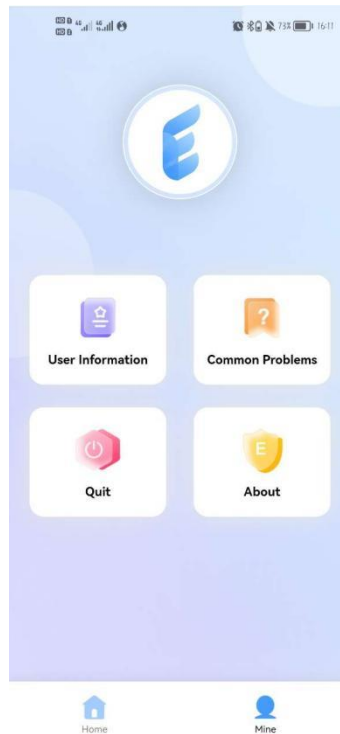

3. Remove Procedures for Modules

3.1. Control Module

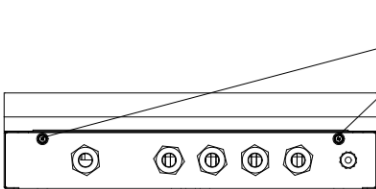
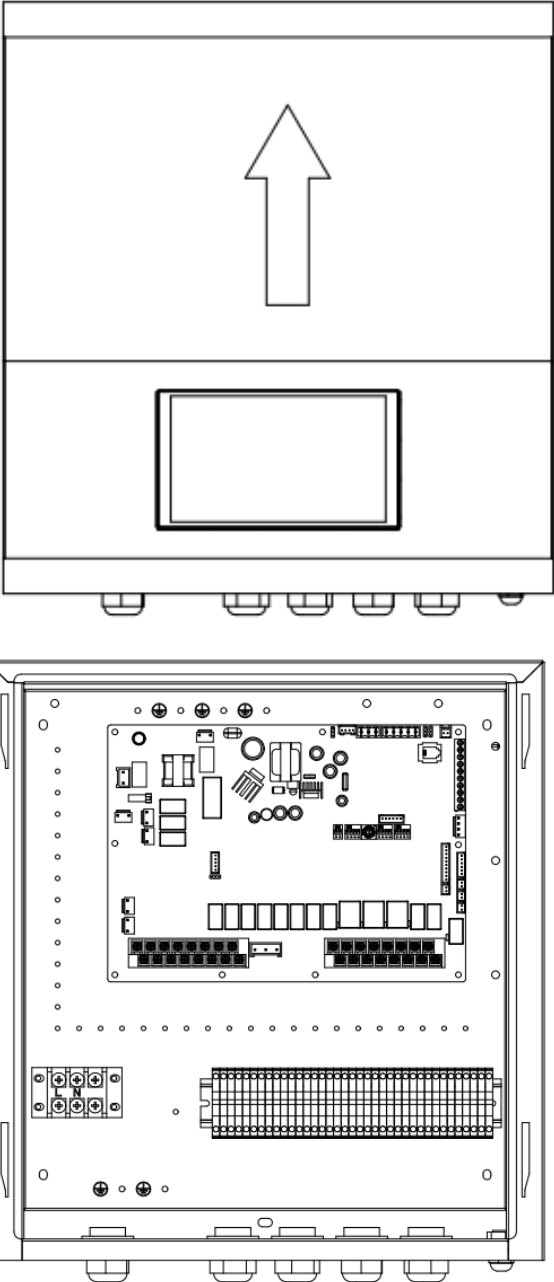
Work Procedure	
<p>1. Remove the Bottom Plate</p> <p>① Remove the two screws on the bottom fixing plate.</p>	 <p>Screws</p>
<p>2. Remove The Upper Front Service Panel</p> <p>① Push the front panel upward to remove it.</p> <p>Note: connection status of the wire controller communication wire</p>	

3.2. Hydraulic Module

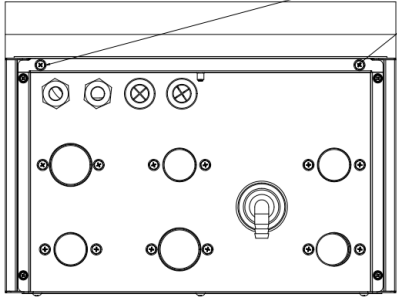
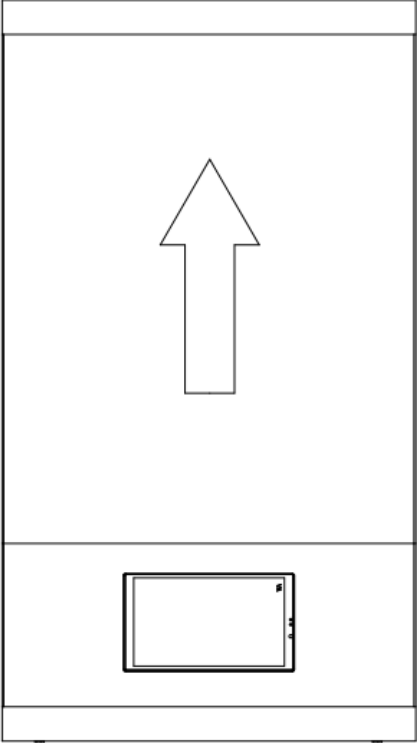
Work Procedure	
<p>1. Remove the Bottom Plate</p> <p>① Remove the two screws on the bottom fixing plate.</p>	 <p>The diagram shows a rectangular bottom plate with various components. Two screws are located at the top corners, indicated by lines pointing to the word "Screws". The plate features several circular ports and a central circular component.</p>
<p>2. Remove The Upper Front Service Panel</p> <p>① Push the front panel upward to remove it.</p> <p>Note: connection status of the wire controller communication wire</p>	 <p>The diagram shows a vertical rectangular panel. A large upward-pointing arrow is centered on the panel, indicating the direction to push it. At the bottom of the panel, there is a smaller rectangular component, likely the wire controller communication wire connection point.</p>

3. Remove the Electric Box Cover

① The initial password of the electrical box is 000.

② The electrical box cover can be opened by rotating the password lock.

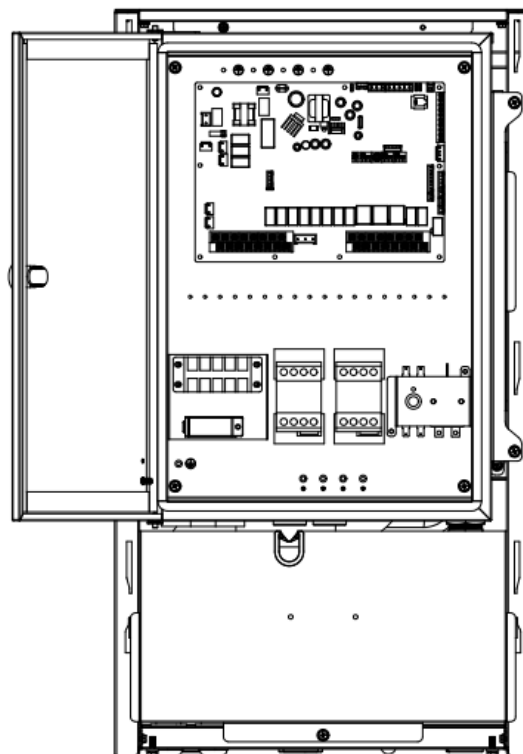
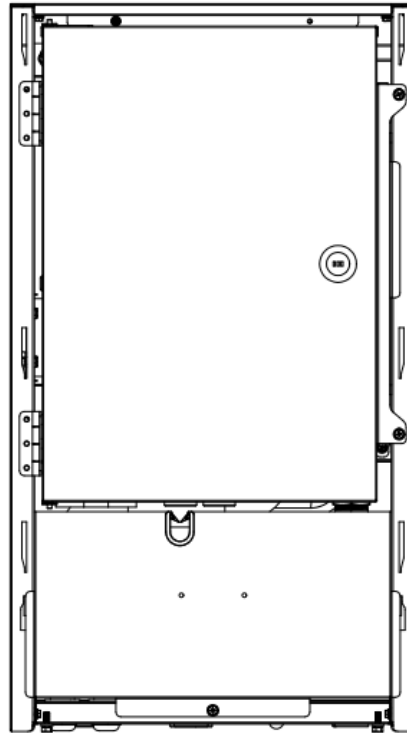

4. Remove The Electrical Box

- ① Remove the three screws marked on the right picture.
- ② Then rotate the electrical box to view the internal structure of the small water conservancy module.

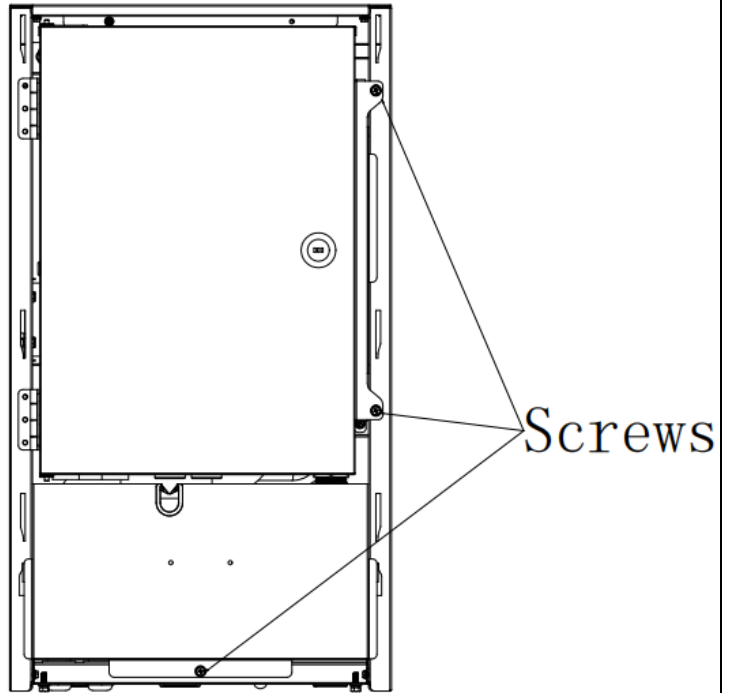

3.3.DHW Hydraulic Module

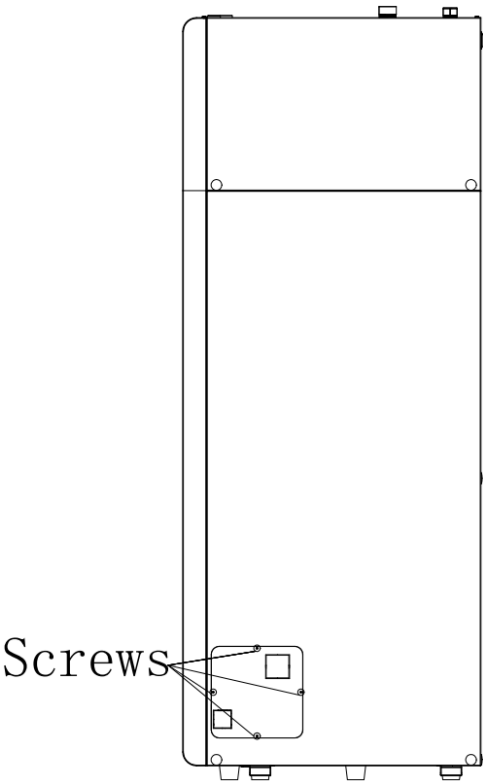
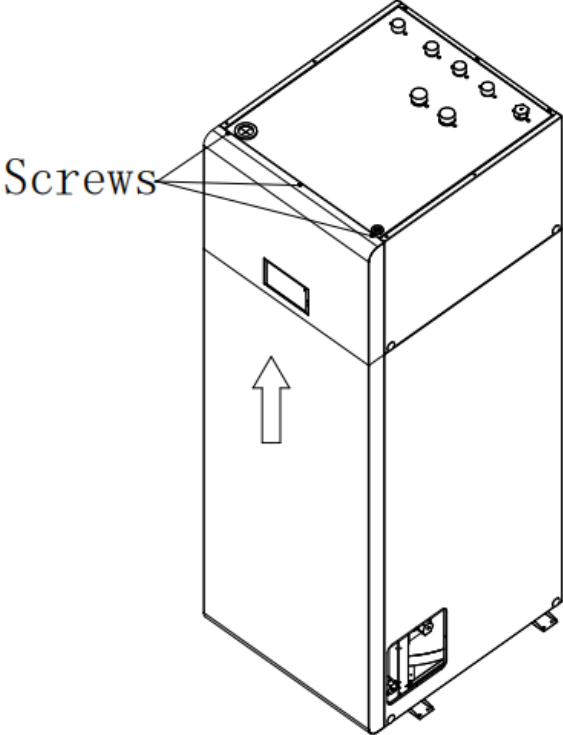
Work Procedure	
<p>1. Remove the Right Plate</p> <p>① Remove the four screws to the right.</p>	 <p>The diagram shows a vertical rectangular unit. A callout box labeled 'Screws' points to four screws on the right side of the unit: two are located near the top edge, and two are near the bottom edge.</p>
<p>2. Remove The Upper Front Service Panel</p> <p>① Remove the two screws shown in the figure, then, remove the communication connector of the wired controller.</p> <p>② Remove the upper front panel.</p>	 <p>The diagram shows a 3D perspective view of the unit. A callout box labeled 'Screws' points to two screws on the top edge of the upper front panel. An upward-pointing arrow is drawn on the front panel to indicate the direction of removal.</p>

3. Remove the Electric Box Cover

① Remove the four screws from the electric box cover.

② Remove the box cover.

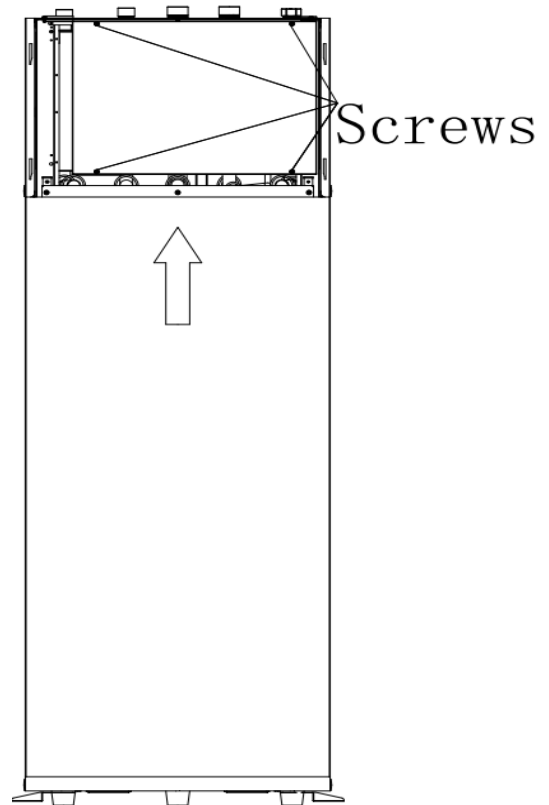

4. Remove The Front Panel

① Remove the three screws from the front panel.

② Remove the front panel.

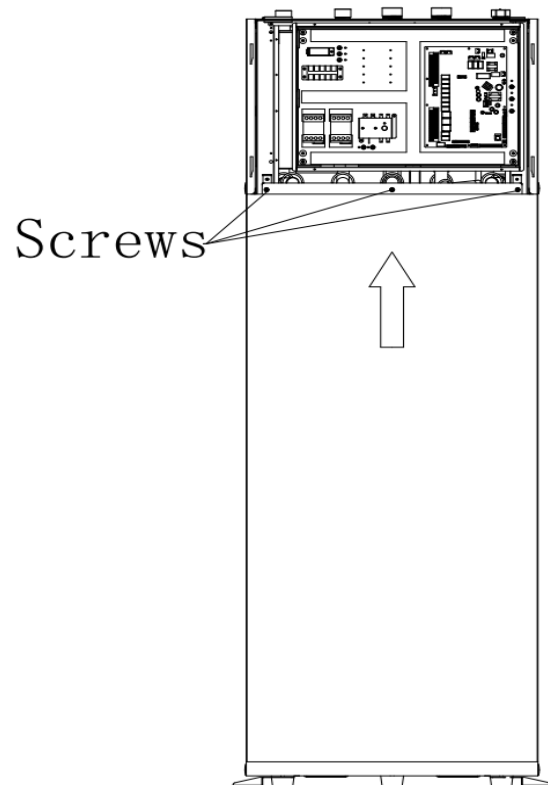

5. Remove The Upper Coaming

① After removing the rubber plugs on the left and right panels the under of upper coaming, remove the internal screws.

② Then take out the top screws and remove the upper coaming backwards.

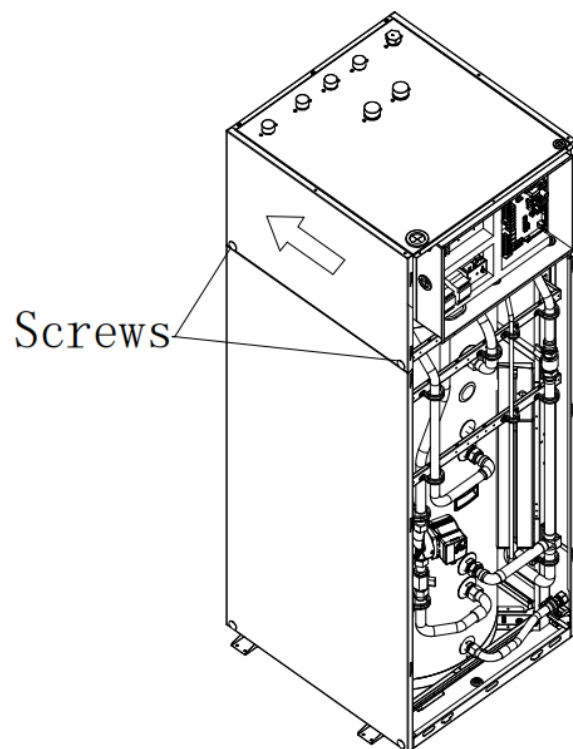
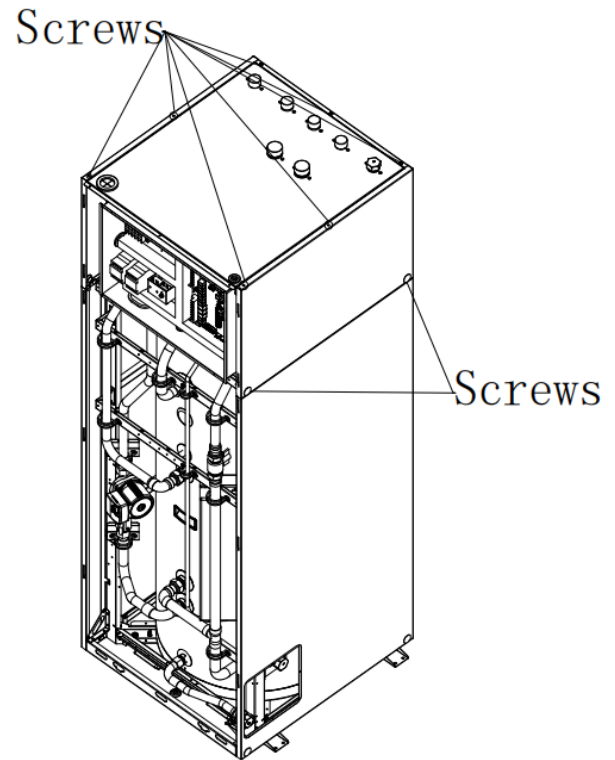

6. Remove The Back Panel

① After removing the rubber plugs on the up and down of the back panel, remove the internal screws.

② Then take out the back panel backwards.

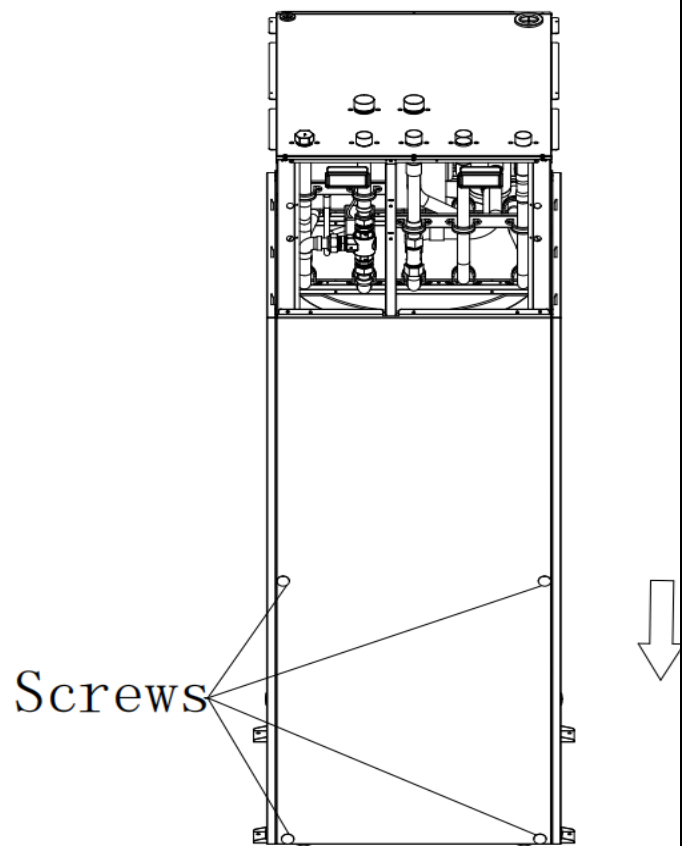

7. Remove the left and right panels

- ① After removing the front and rear screws of the left and right panels in Figures 1 and 2;
- ② Remove the rubber plugs at the bottom of the left and right panels in Figures 3 and 4, and remove the internal screws;
- ③ Then remove the screws in the parts; finally, remove the left and right panels to the left and right respectively.

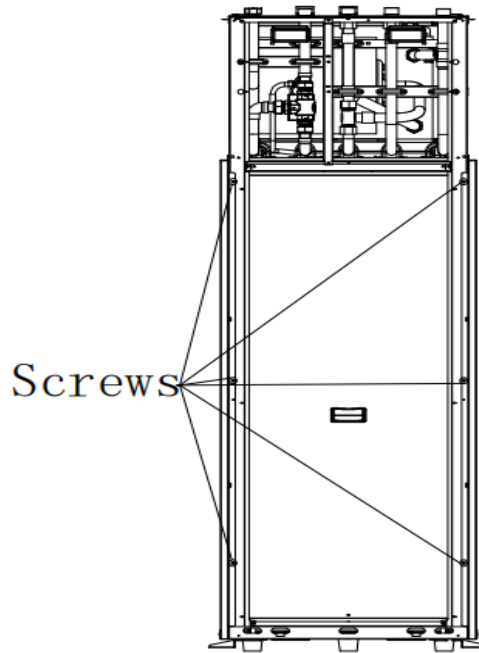

Figure 1

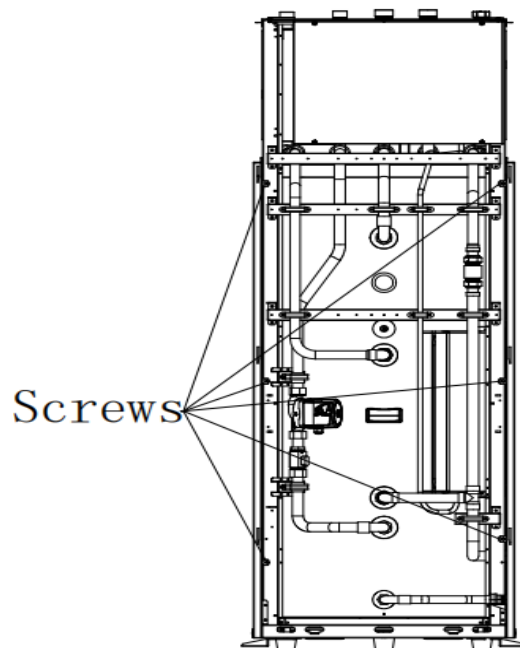
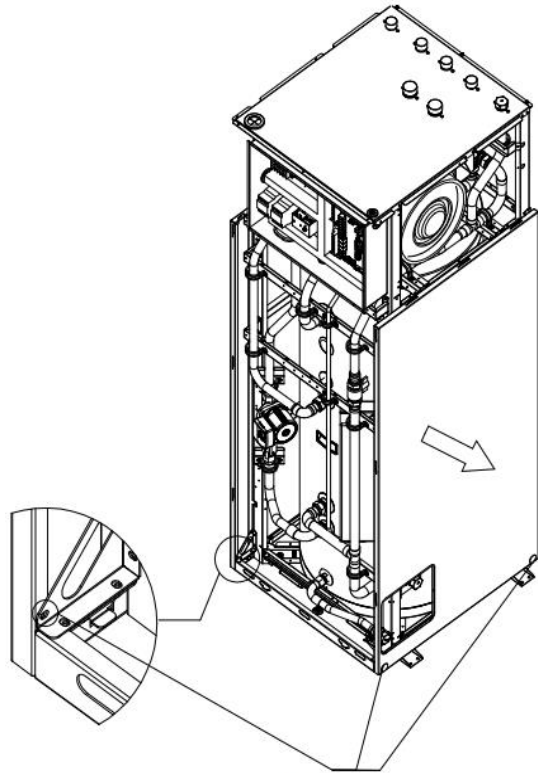
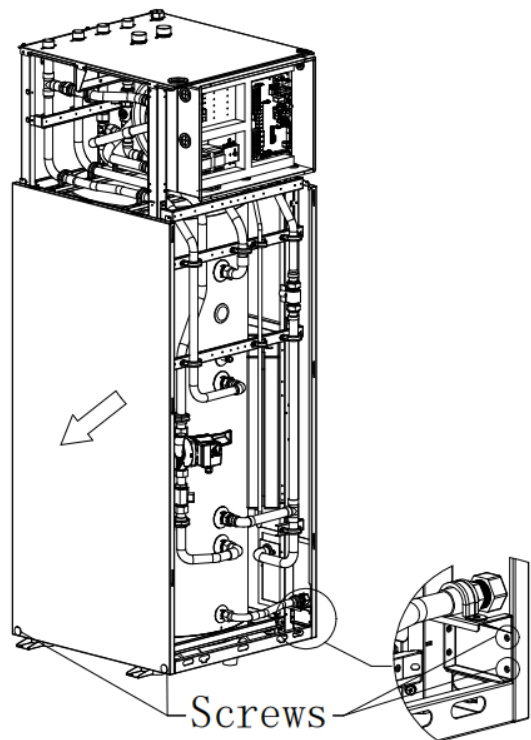

Figure 2



Screws
Figure 3



Screws
Figure 4

